

## A Novel Wind Energy Conservation System using Dual Rotor Wind Turbine Generator

N. Prakash and Ranithottungal  
Department of EEE, Kumaraguru College of Technology,  
Coimbatore, Tamil Nadu, India

**Abstract:** All renewable energy technologies are not appropriate to all applications or locations. However, as with conventional energy production, there are several issues to be considered. In this study, researchers have proposed a new Wind Turbine Generator System (WTGS). The system, allows both the conductor system and the magnetic system to rotate independently. Normal generators use a rotation of either of the systems to produce power. Hence, the relative motion is equal to the speed of rotation of that component alone. Whereas in the innovation researchers employ a technique in which both the systems are rotated in opposite directions which doubles the relative motion and thereby, producing optimum power at very low speeds. This model will have two concentric rotors. One carrying the field and the other carrying the conductors, placed within the field rotor. The field rotor will be rotated in one direction while the rotor with the conductors will be rotating in the opposite direction. The proposal is to increase the relative motion by combining the above two methods and hence bring in an increase in the output voltage.

**Key words:** Dual Rotor Wind Turbine Generator System, modeling and simulation, blade pitch control, Nonlinear Simulation Software, wind energy

---

### INTRODUCTION

The energy sources used to make electricity can be renewable or non-renewable but electricity itself is neither. Large-scale electric generators such as coal plants or large wind farms are connected to the transformers that increase the electricity's voltage or potential energy, enabling it to be sent via transmission lines over long distances. Transmission lines carry electricity to substations equipped with other transformers that decrease the voltage from there, the low-voltage electricity is carried on distribution lines to industrial, commercial and residential customers (Wind Force, 2005). Electricity is a secondary energy source, meaning that it comes from the conversion of other sources of energy such as coal, natural gas, oil, wood and nuclear power. The energy sources used to make electricity can be renewable or non-renewable but electricity itself is neither. It can be considered a carrier of energy rather than an energy source. Electricity is generated by an electric generator which is a device that converts mechanical energy to electrical energy. A generator forces electric charge (usually carried by electrons) to flow through an external electrical circuit. The source of mechanical energy may be a reciprocating or turbine steam engine, water falling through a turbine or waterwheel, an internal combustion engine, a wind turbine, a hand crank, compressed air or any other source of mechanical energy.

An energy crisis is any great bottleneck or price rise in the supply of energy resources to an economy. Also, researchers find the prime importance of using renewable energy resources as all the non-renewable energy resources are almost at the verge of its extinction. To combat global warming and the other problems associated with fossil fuels, researchers must switch to renewable energy sources like sunlight, wind and biomass (Maalawi and Badr, 2003). All renewable energy technologies are not appropriate to all applications or locations. However, as with conventional energy production, there are several issues to be considered (Habali and Saleh, 1995).

Wind is commercially and operationally the most viable renewable energy resource and accordingly, emerging as one of the largest sources in terms of the renewable energy sector. Wind is the natural movement of air across the land or sea. Wind is caused by uneven heating and cooling of the earth's surface and by the earth's rotation. Land and water areas absorb and release the different amount of heat received from the sun. As warm air rises, cooler air rushes in to take its place, causing local winds. The rotation of the earth changes the direction of the flow of air (Devinant *et al.*, 2002).

Wind electric generator converts kinetic energy available in wind to electrical energy by using rotor, gearbox and generator. The wind turns the blades of a windmill-like machine. The rotating blades turn the shaft

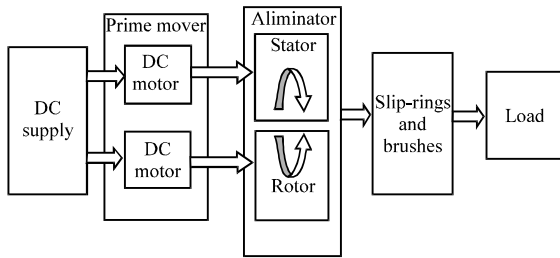

Fig. 1: Over all block diagram of the system

to which they are attached. The turning shaft typically can either power a pump or turn a generator which produces electricity. Most wind machines have blades attached to a horizontal shaft (Muller *et al.*, 2002; Zhang *et al.*, 2004). This shaft transmits power through a series of gears which provide power to a water pump or electric generator. These are called horizontal axis wind turbines. There are also vertical axis machines such as the Darrieus wind machine which has two, three or four long curved blades on a vertical shaft and resembles a giant egg beater in shape (Hoffman, 2002). The overall block diagram of the proposed system is shown in Fig. 1. The main objective of this study is:

- Increase the relative motion between conductor system and field system
- Reduce the cut-in speed for power generation
- Produce rated output at the mean wind speed
- Provide constant power from wind turbines
- Make wind power available throughout the year

### METHODOLOGY

**Existing method:** Generators convert mechanical energy into electrical energy. This conversion is brought about by providing a relative motion between the field and the conductors which induces an emf in the conductors. The relative motion is achieved by keeping the field stationary and rotating the conductors within the created field (Magnusson, 1997; Wang and Coton, 2001; Lee, 2005). The routing field system is shown in Fig. 2. If the field is rotating at a speed 'x' and the relative speed is again given by 'x' itself.

**Proposed method:** The proposal is to increase the relative motion by combining the above two methods and hence bring in an increase in the output voltage. This model will have two concentric rotors. One carrying the field and the other carrying the conductors, placed within the field rotor. The field rotor will be rotating in one direction while the rotor with the conductors will be rotating in the opposite direction. Since, the rotors will be rotating in

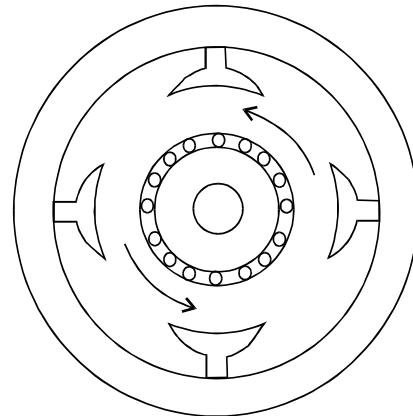

Fig. 2: Rotating field system

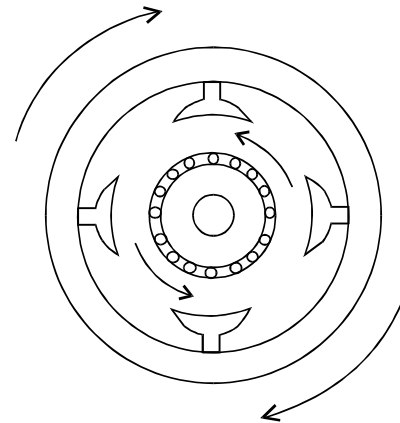

Fig. 3: Rotating field and rotating conductor system

opposite directions the relative motion is increased. The rotating field and rotating conductor system is illustrates in Fig. 3. If the field is rotating at a speed 'x' and the conductors at a speed 'y' then the relative speed is given by 'x+y'.

As the conductors rotate inside the field the cutting of flux induces an emf in it. The magnitude of emf induced is given by:

$$E = \phi Z N P 60 A$$

Now that the speed 'N' is increased, the induced emf should increase. Researchers will be using wind energy to as the prime mover. So, researchers have an increased output from the same machine with some modifications.

Thus, given the output the size of the machine and hence the cost is reduced. The machine, allows both the conductor system and the magnetic system to rotate independently. Normal generators use rotation of either of the systems to produce power. Hence, the relative motion is equal to the speed of rotation of that component alone.

Whereas, in the innovation researchers employ a technique in which both the systems are rotated in opposite directions which doubles the relative motion and thereby, producing optimum power at very low speeds. The proposed system power supply is shown in Fig. 4.

The proposal uses the same wind to rotate both magnetic system and the conductor system in opposite direction. This multiplies the speed and increases the relative motion between the two systems therefore producing maximum power at mean wind velocity (reduced).

Let us consider two cases. One which uses the same prime mover or a single turbine to rotate both the systems and the other which uses two turbines for rotating both the systems.

**Case 1:** Let the rotor diameter = 10 m, wind speed = 6 m sec<sup>-1</sup>. Theoretical power that can be developed = 10.43 kW. Applying Betz limit researchers have power = 2.4 kW. This is the power that can be developed when only one rotation is present. If both the systems are rotating then. For the same rotor diameter, the wind speed is considered to be decreased because of the additional work done to rotate the second system. So, the wind speed = 5 m sec<sup>-1</sup>. But the twin rotations double the relative motion. Hence, the relative motion will be equal to the one when the wind speed is 10 m sec<sup>-1</sup>. Therefore, the power developed (practical) = 11 kW.

**Case 2:** Rotor 1 diameter = 10 m; rotor 2 diameters = 10 m; wind speed = 6 m sec<sup>-1</sup>. Due to the rotation of the systems in opposite directions the relative motion is equal to that when the wind speed is 12 m sec<sup>-1</sup>. Thus, the power developed = 20 kW. From the calculations it is clear

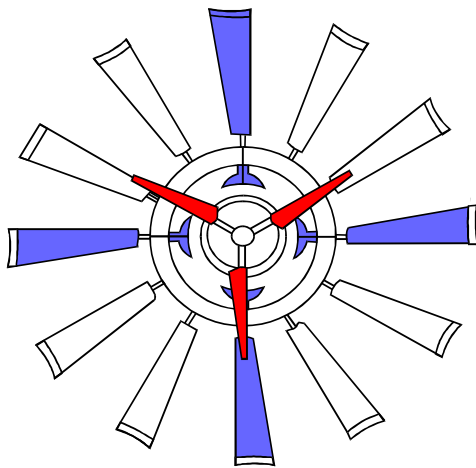

Fig. 4: Power supply block diagram

that the power produced by the machine has increased many times than that one produced by conventional machine at the same speed. Both the cases have its own advantages because both the systems are rotating. Increasing the relative motion between the magnetic system and the conductor system by rotating both in opposite directions, researchers decrease the cut in velocity of power generation using turbines. This makes wind power reliable and available throughout the year. the innovation is mainly aimed at wind power generation. Therefore, researchers increase the capacity factor of wind turbines at least by 25%.

Wind power is considered non reliable because the power generation largely depends on wind velocity, which for most part of the year is below the minimum required velocity for usable power generation (except for 3-4 months). Therefore, when total power generation for a particular area is considered the power that is generated by wind is generally not taken into account because of its non-reliability.

#### HARDWARE DESCRIPTION OF THE PROPOSED SYSTEM

The proposed system consists of the following components:

- Alternator
  - Field system
  - Conductor system
- Slip rings and brush assembly
- Prime mover
- Drive assembly

**Alternator:** An alternator is an electromechanical device that converts mechanical energy to electrical energy in the form of alternating current. Most alternators use a rotating magnetic field but linear alternators are occasionally used. The basic principle of operation of AC generators is based on Faraday's Law of Electromagnetic Induction which states that "Whenever a conductor cuts a flux, an emf is induced. The amount of emf induced in conductor is proportional to rate of change of flux and the flux linked with the conductor". Typically, a field system consisting of magnets provides the flux. A set of conductors are wound in coils on an iron core. The stationary part is called the stator while the rotating part is the rotor. In some machines the field system is the rotor while the conductors are stationary. In other machines it is vice versa. The field cuts across the conductors, generating an induced EMF (Electromotive Force) as the mechanical input causes the rotor to turn. Alternators, according to their construction are divided into the following two classifications:

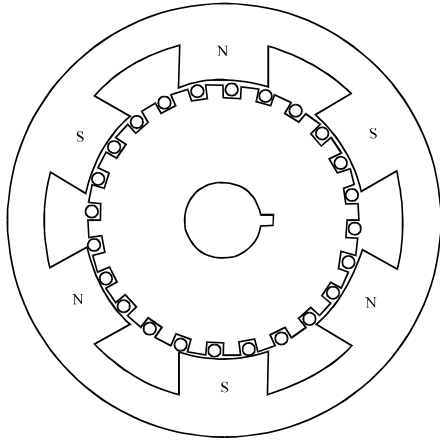

Fig. 5: Revolving-armature type alternator

- Revolving-armature type
- Revolving-field type

**Revolving-armature type alternator:** It has stationary field poles and revolving armature. It is usually of relatively small kVA capacity and low voltage rating. It resembles a DC generator in general appearance except that it has slip-rings instead of a commutator. The field's excitation must be direct current and therefore, must be supplied from an external direct current source. The revolving-armature type alternator is shown in Fig. 5.

When the rotor rotates, the conductors cut the magnetic flux produced by the stationary poles hence emf is induced in them. The magnetic poles are alternatively N and S. They induce an emf and hence current in armature conductors which flows in one direction and then in the other. Hence, an alternating emf is produced in the rotating conductors whose frequency depends on the number of pole pairs moving past a conductor in one second and whose direction is given by Fleming's Right-Hand rule.

**Revolving field type alternator:** It has a stationary armature or stator, instead of which the field poles rotate. Most alternators are of the revolving field type in which revolving field structure or rotor has slip rings and brushes to supply the excitation current from an outside or source. The armature coils are placed in slots in a laminated core called the 'stator' which is made up of thin steel punching or laminations securely clamped and held in place in the steel frame of the generator. Usually, the field voltage is between 100 and 250 V and the amount of power delivered to the field circuit is relatively small. The revolving field type alternator is given in Fig. 6.

When the rotor rotates, the stator conductors are cut by the magnetic flux, hence emf is induced in them. Because the magnetic poles are alternatively N and S.

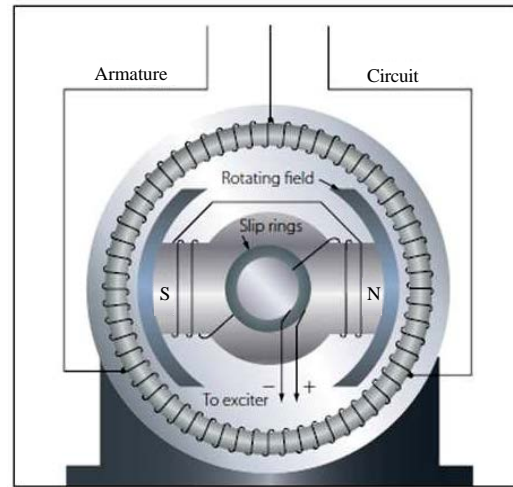

Fig. 6: Revolving field type alternator

They induce an emf and hence current in armature conductors which flows in one direction and then in the other. Hence, an alternating emf is produced in the stator conductors whose frequency depends on the number of N and S poles moving past a conductor in one second and whose direction is given by Fleming's Right-Hand rule.

### PROPOSED TWIN TURBO ALTERNATOR

The proposed system is named twin turbo which means two rotations. The machine has two rotors which are capable of rotating in opposite directions. It has two parts, namely:

- Field system (rotor 1)
- Conductor system (rotor 2)

**Field system:** It is a single piece of hollow cylinder made of cast iron. The frame along with the field system is mounted on a shaft with the help of bearings. This enables the frame to be rotated along with the field. The frame on the outer surface has a provision for attaching a belt. It also consists of two rails that prevent the belt from slipping. It is with the help of the belt, it is connected to the prime mover and made to rotate. This part houses and protects the field system and the other parts of the machine.

The field system provides the magnetic flux and therefore, the necessary excitation for the operation of the machine. It consists of six permanent magnetic poles, i.e., three pole pairs. These poles are made up of Ferro-magnetic materials which are fixed to the inner surface of the frame with the help of industrial paste. The proposed method field system is shown in Fig. 7.

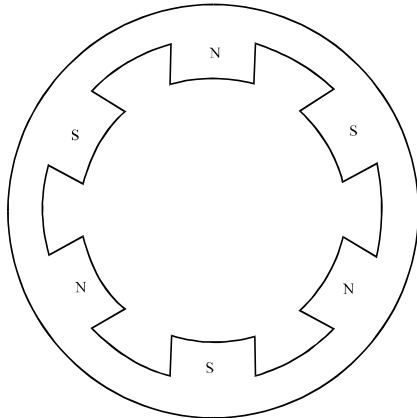

Fig. 7: Proposed method field system

**Conductor system:** It is in this part of the machine where the electro-mechanical energy conversion takes place. It is a cylindrical body that rotates between the magnetic poles. It consists of an armature placed on a shaft. The shaft is mounted on two supports with the help of bearings, so that it can rotate freely. The armature core is made up of laminations that reduce eddy current loss. The outer surface of the armature core consists of slots in which the copper conductors are housed. The machine has 24 slots. The end of the shaft also consists of pulley type arrangement for housing a belt, enabling it to be rotated by means of a prime mover. The function of slip-rings is to collect the current generated from the armature and convert it to unidirectional current. It is a cylindrical structure with a number of segments equal to the number of the armature coils. The current in the slip-rings is tapped out to the external circuit with the help of brushes, made of carbon.

**Machine configuration:** The field system and the conductor system can be configured in two ways:

- Field-conductor independent configuration
- Field-conductor dependent configuration

**Field-conductor independent configuration:** As proposed earlier the field system and the conductor system are to rotate, in opposite directions. In this configuration the motion of the field and the conductor system are independent of each other. If for example, wind turbine is considered as the prime mover, both the field assembly and the conductor assembly will be independently connected to the turbine or might possess blades of their own. This said there is no relation between the speeds of both the rotors. The proposed field-conductor independent configuration is shown in Fig. 8. The frame

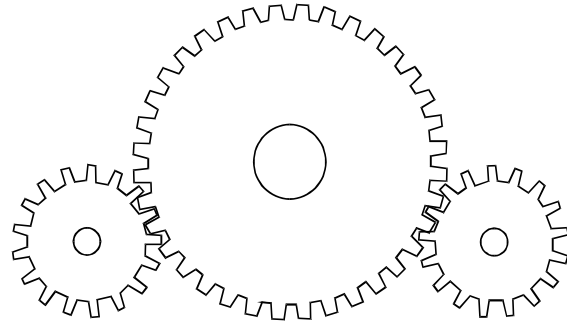

Fig. 8: Field-conductor independent configuration

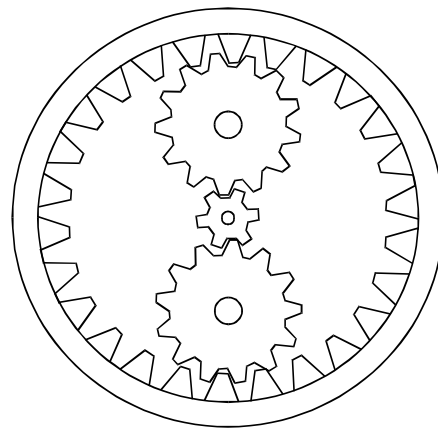

Fig. 9: Field-conductor dependent configuration

in the middle is connected to the prime mover by means of two gears while the armature within the frame has a separate connection with the prime mover.

**Field-conductor dependent configuration:** Here, in this configuration, the field system and the conductor system are connected by means of gears. Therefore, their motions are dependent on each other and the speeds are related by the gear ratio. In this configuration, the field will be connected to the prime mover along the gears while the armature which is connected with the field assembly may or may not be coupled with the prime mover. The armature in the middle is in connection with the outer field. The machine uses independent configuration where both the field system and the conductor system rotate independent of each other. The proposed field-conductor dependent configuration is given in Fig. 9.

**Winding:** The armature windings comprise a set of coils embedded in the slots uniformly spaced round the armature periphery. The emfs are induced in the armature coils due to the relative motion between them and the flux in the air gap is established by the field. The armature

coils are connected to slip rings which are tapped by stationary brushes. Here, wave winding is used where finish end of one coil under one pole pair is connected to start of coil under next pole pair. The winding has two parallel paths and hence only two brushes are used.

**Slip rings and brushes:** The arrangement which is used to collect the AC induced emf from rotating armature and is given to external circuit is called slip ring and brush assembly. In this case, the armature consists of single phase winding and the AC emf is induced in this winding. The single phase supply is available at the output terminals. But these terminals are rotating and hence the stationary load cannot be connected. Hence, eslip rings are made up of the conducting material and are mounted on the shaft. Hence, single phase supply is available at the rotating slip rings. Brushes are connected to the slip rings and therefore the single phase supply is available at the output.

The mechanical power for the rotation of two rotors is given using two DC motors one for the conductor system and one for the field system. Two DC motors are excited from two separate DC supply systems. The prime movers and the rotors are mechanically coupled by a belt drive whose heads are of the same circumference as the rotor heads. This allows direct speed control and because of the 1:1 ratio the speed of rotation of the rotor is equal to the speed of rotation of the prime mover. Armature voltage control method is employed for the speed control of both the prime movers. The circuit diagram is shown in Fig. 10.

**Working:** When energy is supplied to the prime mover 1, it rotates thereby rotating the field system. The machine is in independent configuration. The prime mover 2 is also excited which rotates the conductor system in a direction opposite to that of the field system. As a result, the field system and the armature rotate in opposite directions. Consequently the flux lines are cut by the conductors which induce an emf in the conductors. The relative motion is increased because of the dual rotation which will increase the induced emf. The general equation for emf induced in any alternator is given by  $E = 4.44 KN\Phi$ .

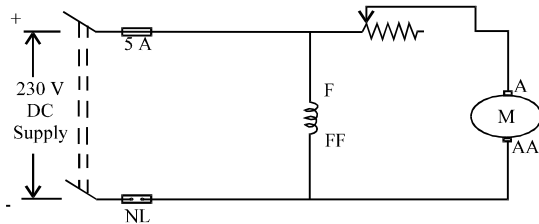

Fig. 10: Circuit diagram of the prime mover

EMF induced due to rotor<sub>1</sub> is given by  $E_1 = 4.44 KN_1\Phi$ . EMF induced due to rotor<sub>2</sub> is given by  $E_2 = 4.44 KN_2\Phi$ . According to superposition theorem the total induced emf is given by:

$$E = E_1 + E_2 = 4.44 K\Phi (N_1 + N_2)$$

Where:

- $N_1$  = Speed of rotor<sub>1</sub>
- $N_2$  = Speed of rotor<sub>2</sub>
- $E > E_1$  and  $E_2$  = Volts

### EXPERIMENTAL SETUP

The alternator and the two prime movers are fixed firmly on the steel bed with the help of screws to avoid vibration during running. The prime mover 1 is connected to the rotor<sub>1</sub> with the help of a belt arrangement system directly to the shaft whereas the prime mover 2 is connected to the rotor 2 with the help of a belt arrangement system but to a steel drum which is coupled to the shaft. The steel drum is used to compensate for the 1:1 ratio for the rotor 2 and is of the same circumference as rotor 2. Experimental setup of the proposed system is shown in Fig. 11.

**When rotor 1 is alone running:** Now the rotor 2 is kept stationary and rotor 1 is alone rotated with the help of prime mover 1. The speed of the prime mover 1 is controlled by armature control method and various parameters are noted for different speeds. The observations are given as Table 1.

**When rotor 2 is alone rotated:** Now the rotor 1 is kept stationary and rotor 2 is alone rotated with the help of

Table 1: Experimental results of various parameters

| Rotor 1 speed (RPM) | Voltage (V) | Frequency (Hz) |
|---------------------|-------------|----------------|
| 300                 | 72          | 10             |
| 600                 | 138         | 20             |
| 900                 | 202         | 30             |



Fig. 11: Experimental setup of the proposed system

**Table 2: Experimental results when rotor 2 is alone rotated**

| Rotor 1 speed (RPM) | Rotor 2 speed (RPM) | Voltage on no load (60 W) (V) | Voltage on load (V) | Frequency on no load (Hz) | Frequency on load (60 W) (Hz) |
|---------------------|---------------------|-------------------------------|---------------------|---------------------------|-------------------------------|
| 300                 | 300                 | 138                           | 140                 | 20                        | 20                            |
| 450                 | 450                 | 200                           | 192                 | 30                        | 29                            |
| 300                 | 600                 | 200                           | 194                 | 30                        | 29                            |

**Table 3: Experimental results when rotor 1 is alone rotated**

| Rotor 2 speed (RPM) | Voltage (V) | Frequency (Hz) |
|---------------------|-------------|----------------|
| 300                 | 72          | 10             |
| 600                 | 134         | 19             |
| 900                 | 196         | 29             |

prime mover 2. The speed of the prime mover 2 is controlled by armature control method and various parameters are noted for different speeds. The observations are given as Table 2. Now when both the rotors are rotated simultaneously in opposite direction with the help of two prime movers, the voltage gets doubled for the same speed on each rotor thus reducing the cut in speed. The observations are in Table 3.

**CONCLUSION**

It is evident that wind flow is not uniform across the country. Also, wind power is below the cut-in speed in most of the remote locations where other sources of energy cannot be utilised effectively. So, wind farms cannot be installed in those places. There is a possibility of generation of power by the wind farms if the cut-in speed can be reduced to a greater extent. the project provides a solution for generation of power in wind mill through a special machine which can generate even in lower cut-in speeds. So, this system can be made to use in all remote areas for local power generation and utilization. This innovative idea could possibly be the ideal solution for the ever-growing power scarcity in the country.

**RECOMMENDATIONS**

Researchers find that most of the wind turbines are stalled when enough wind velocity is not available. Using this alternator it is possible to obtain wind power throughout the year. Thus, this project will bring a remarkable change in generating power from all renewable sources of energy thereby overcoming the problem of energy crisis. This is not only applicable for wind turbine but in all applications where low speed and high torque is present. An initial analysis with the model revealed that there are no technical barriers to wind energy generating a significant part of the electricity supply. Technical measures are available to resolve any unexpected

problems that arise. Research has shown that the measures chosen are strongly dependent on the type of wind turbine used and this must therefore be taken into account. So, it is only the place where researchers install and the wind velocity matters. With the help of this twin turbo alternators it is possible to install wind turbines wherever possible even at the lowest velocity of wind thereby meeting the energy demand.

**REFERENCES**

Devinant, P., T. Laveme and J. Hureau, 2002. Experimental study of wind-turbine airfoil aerodynamics in high turbulence. *J. Wind Eng. Ind. Aerodynamics*, 90: 689-707.

Habali, S.M. and A.I. Saleh, 1995. Design and testing of small mixed airfoil wind turbine blades. *Renewable Energy*, 6: 161-169.

Hoffman, R., 2002. Comparison of control concepts for wind turbines in terms of energy capture. D17 Darmstadter Dissertation. <http://tuprints.ulb.tu-darmstadt.de/226/1/Diss.pdf>.

Lee, C.S., 2005. Optimal aerodynamic design and load calculation for blade of 1 MW horizontal axis wind turbine. M.Sc. Thesis, Chonbuk National University, Korea.

Maalawi, K.Y. and M.A Badr, 2003. A practical approach for selecting optimum wind rotors. *Renewable Energy*, 28: 803-822.

Magnusson, M., 1997. Near-wake behavior of wind turbines. *J. Wind Eng. Ind. Aerodynamics*, 69: 413-422.

Muller, S., M. Deicke and R.W. de Doncker, 2002. Doubly fed induction generator systems wind turbines. *IEEE Ind. Appl. Magazine*, 8: 26-33.

Wang, T. and F.N. Coton, 2001. A high resolution tower shadow model for downwind wind turbines. *J. Wind Eng. Ind. Aerodynamics*, 89: 873-892.

Wind Force, 2005. A blueprint to achieve 12% of the world's electricity from wind power by 2020. Greenpeace.

Zhang, X., D. Xu and Y. Liu, 2004. Intelligent control for large-scale variable speed variable pitch wind turbines. *J. Control Theory Appl.*, 2: 305-311.