

The Unit of a Grinding and Material Classification on the Basis of a Mill of Desintegrating Type

Igor Alexandrovich Semikopenko, Sergey Vladimirovich Vyalykh and
Alexandr Alexandrovich Zhukov
Belgorod State Technological University Named after V.G. Shukhov,
Kostyukova Street 46, 308012 Belgorod, Russia

Abstract: The research urgency in the field of building materials is determined by crushing a large extent influenced by grinding on the technological properties of the material. The need to improve the dispersion of building materials in the form of the final product as well as intermediate products in the processing steps required to create new and improved types of grinding units. This study describes the problems of grinding and classification. For the purpose of combining the above processes within a single unit, observing the principle of staging, grinding machine and material classification designed. Mathematical description of the processes of grinding and classification of materials were developed. Researchers prove the need and opportunity to use methods of calculating the geometric parameters in the main nodes of the particle acceleration in the unloading of the machine grinding and classification of materials, taking into account the structural and technological features.

Key words: Disintegrator, classification, grinding, particle, single unit

INTRODUCTION

Now it is difficult to imagine any modern production without crushing the input of raw materials and semi-finished products. It should be noted that the requirements for the quality of the products and technologies of grinding constantly increase, especially such indicators as specific energy cost of the process of crushing, grinding equipment reliability, obtaining a given particle size distribution of the material. Extremely wasteful expenditure of energy input, high consumption of material elements operating force us to search an alternative for grinding units squashing action, new ways of crushing and grinding circuits and as follows the new equipment.

The shredding machines percussion is undoubtedly much more promising in this respect (Hint, 1962). High grinding efficiency, easy maintenance, capability of integration into existing production lines are not a complete list of benefits shredder percussion. The output of some modern models of mills Impact on high-speed (150 m sec^{-1} or more) modes allowed to withdraw grinding processes in the areas of active influence on the material being ground, to a new level.

THE MAIN PART

It is known that increasing of the surface area of the finished product reduces the performance while increasing energy costs and reducing the life of the equipment (Poliad and Cochet, 1990). Durability of work items chopper is often the limiting factor when choosing the type of mill. To increase the reliability of the choppers, in terms of wear and tear, it is necessary to move from particle size reduction of the body to the work items of the particles. This can be achieved if the process of grinding is arranged on the layer material of counterflow principle used when the particles are loaded in a collision with each other in opposing currents (Giersiepen, 1973). The loading of the granular material in the energetically favorable mode in conjunction with the withdrawal from the area of particle size reduction, corresponding to the final product can be fully effected by combining the processes of grinding and classification within a single unit, respecting the principle of the stages (Bogorodskiy, 1982).

For this purpose, a grinding machine and classifying materials which comprises two mills: countercurrent centrifugal mill and mill type disintegrator were developed. The counterflow centrifugal mill contains two spiral

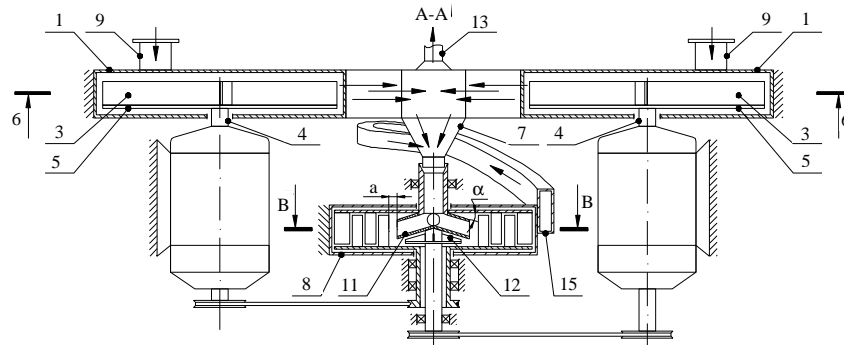

Fig. 1: The machine grinding and classifying materials

casing 1, connected by a tangential channel 2. In each case a rotor 3 which comprises a drive shaft 4 and 5 which are fixed by spreader blade 6, bent towards the rotor. In a tangential channel 2 is unloading pipe 7, equidistant from the axis of rotation of the rotors and directed into the grinding chamber mill disintegrator type 8 as well as nipple discharge 13 fine material (Fig. 1) (Voronov *et al.*, 2009).

Submission of shredded material in a centrifugal mill is counter-screw feeder. Disintegrator mill type comprises a rotor with two concentric rows of work items that are rotating in opposite directions. To increase the grinding efficiency and performance of the mill type disintegrator in the central grinding chamber at the outlet from the discharge pipe 7 are installed obliquely cylindrical spreader tubes 11, bent in a direction opposite the direction of rotation of the upper disc. For unloading the coarse fraction type disintegrator mill housing has a tangential outlet 10 connected by a spiral tube 15 with a conical part of the discharge pipe 7 and for unloading the finished product in the casing pipe 14 is normal. Rotors disintegrator mill and centrifugal-type counter mill is driven by two electric motors.

Grinding and classifying unit operates as follows. The starting material is fed into the hollow loading pipe 9 simultaneously with the same bandwidth and high speed reaches the wheels 5 ($n = 12000 \text{ min}$) with the overlocking blades 6. That's why the boot connectors 9 are offset relative to the axis of rotation of the rotor material to be ground in each time interval is flagged only one of the spreader vanes 6. Particles trapped in the acceleration vanes curved in the direction of rotation of the rotor, collect them due to centrifugal forces and friction. The accumulation proceeds until the material is milled until it fills bends booster blades. Depending on the size and nature of the crushed material loading nozzles 9 are displaced relative to the axis of rotation of the rotor 3 and the tangential channel 2 so that

the smaller particles in the final product discarded zone discharge pipe 13 and the coarse fraction directly to the tangential channel 2 where the two rotors with particle break under the joint collision with each other. In that case, the ground material has a large dispersion, the particles increases torch gathering the disc 5. This is due to the fact that the output of crushed material from the feed pipe 9 particle flow changes direction by almost 90°, so is the inertial separation. Pre-crushed particles under gravity and air flow through the unloading port 7 into the grinding chamber are directed disintegrator mill type and the fine material is discharged through outlet 13 by the exhaust fan.

In the central part of the grinding chamber are spreading nozzles that increase the capacity of the first inner row of elements. Spreading nozzles mounted on the upper horizontal disc at an angle α that is greater than the angle of repose of the material being ground, the distance α between the ends of a spreader nozzle and an operating element exceeds the maximum size of ground particles and a lower horizontal disc spreader nozzles are rigidly fixed blade fan wheel 12 creating the effect of ventilation in the dead zone. The capacity of the loading ramp and mill disintegrator type equal to that of the two filling pipe centrifugal countercurrent mill.

Go through, the ranks of the working elements, the coarse fraction of the material is sent to the tangential discharge opening 10 for regrinding and the finished product is discharged by size through the normal port 14 (Fig. 2 and 3).

Thus, the developed grinding and classifying unit enables to produce high quality material compositions of different materials with a given formulation and particle size distribution.

The mathematical description of the angular spread of the crushed material. Consider the motion of material particles in the centrifugal countercurrent of the machine grinding and classification. First, imagine high-speed disks with 5 straight over clocking blades 6.

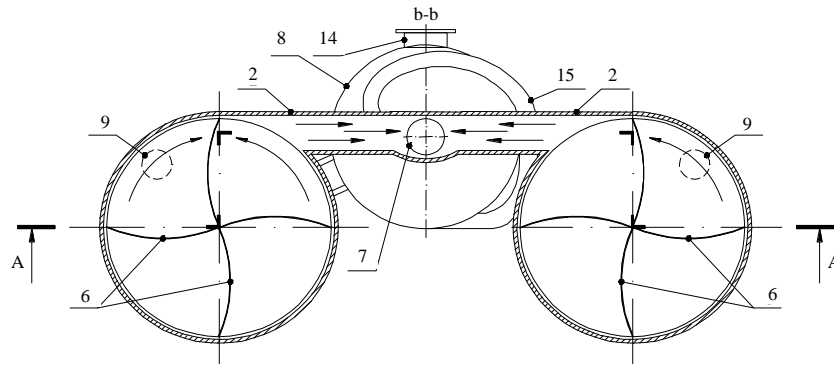

Fig. 2: Camera centrifugal grinding mill counter

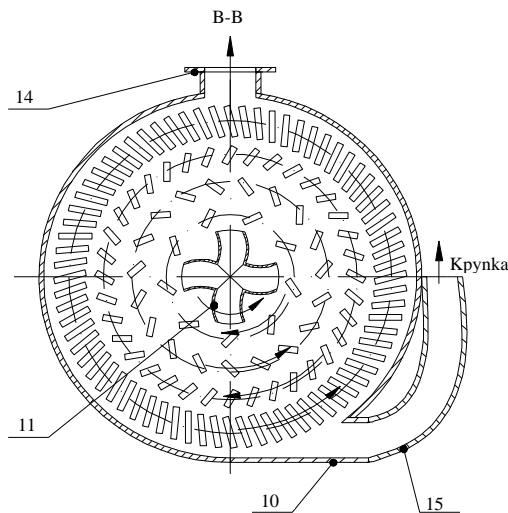

Fig. 3: Camera grinding mill disintegrator type

The height of spreader blades 6, ensuring high-speed movement of the material in a tangential channel 2 is defined as follows. The trajectory which is traversed by the stuff on the vertical portion of the pipe boot 9 is given by:

$$Z = \frac{gt^2}{2} \quad (1)$$

The angle at which the blade rotates booster 6 at time t at the speed of the rotor is determined from the expression:

$$\varphi = \frac{\omega t}{N} \quad (2)$$

From here we have the time of passage of the material in the vertical pipe portion boot $t = \varphi/\omega$. Substitute the time t in the Eq. 1:

$$Z = \frac{g}{2} \times \frac{\varphi^2}{\omega^2} \quad (3)$$

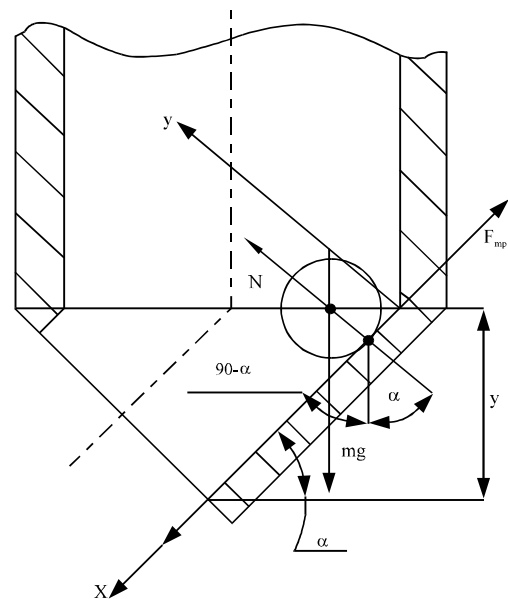

Fig. 4: The scheme for calculation of the motion of the material in the sloping part of the filling pipe

This equation determines the trajectory which is traversed by the material in the vertical section of the pipe boot when you turn the booster on the angle of the rotor blades. In particular, if the rotation angle is $\varphi = \pi/2$:

$$Z = \frac{\pi^2 g}{2 \times \omega^2} \quad (4)$$

For a meeting of the material with a boost shovel we need the shoulder height (the height of the axis Z) satisfies the condition:

$$h \geq z \quad (5)$$

Consider the motion of the material in the sloping part of the filling pipe (Fig. 4); $mx'' =$

$mg \times \sin \alpha - \mu \times mg \times \cos \alpha$ the equation of motion of the particles of the material along the axis ox:

$$\frac{d^2x}{dx^2} = g \times \sin \alpha - \mu \times g \times \cos \alpha = g \times \cos \alpha (\operatorname{tg} \alpha - \mu)$$

$$\mu = \operatorname{tg} \varphi$$

$$\frac{d^2x}{dx^2} = g \times \cos \alpha (\operatorname{tg} \alpha - \operatorname{tg} \varphi)$$

We integrate this expression:

$$\operatorname{tg} \alpha > \operatorname{tg} \varphi, \alpha > \varphi$$

$$x(t) = \frac{g \times \cos \alpha (\operatorname{tg} \alpha - \operatorname{tg} \varphi) \times t^2}{2} + C_1 t + C_2$$

The integration constants are determined from the initial conditions:

$$C_1 = 0, C_2 = l_0$$

$$x(t) = l_0 + \frac{g \times \cos \alpha (\operatorname{tg} \alpha - \operatorname{tg} \varphi) \times t^2}{2}$$

$$t_2 = \frac{\psi}{\omega}; \quad x(\psi) = \frac{d_0}{2} \times \operatorname{ctg} \alpha + \frac{g \times \cos \alpha (\operatorname{tg} \alpha - \operatorname{tg} \varphi) \times \psi^2}{2 \times \omega^2}$$

$$\frac{y}{x} = \operatorname{tg} \alpha; \quad y = x \times \operatorname{tg} \alpha$$

$$y = \frac{d_0}{2} + \frac{g \times \sin \alpha (\operatorname{tg} \alpha - \operatorname{tg} \varphi) \times \psi^2}{2 \times \omega^2} + \frac{\pi^2 g}{2 \times \omega^2}$$

taking into account the movement of material in vertical and inclined sections of boot fitting. Determination of the angular size of the booster unit (rotor blade straight without bends). Determine the time t_1 , the particles of the material required for the passage of the way the sun as it moves from point B (Fig. 5):

$$t_1 = \frac{AC - AB}{v(\rho_1)} = \frac{L - d_0}{v(\rho_1)} \quad (6)$$

Where, according to the results of (Voronov *et al.*, 2008), the particles of material from point B will move at a constant speed:

$$v(\rho_1) = \omega \times \rho_1 \frac{\cos \beta_1 - \mu \sin \beta_1}{2\mu} \quad (7)$$

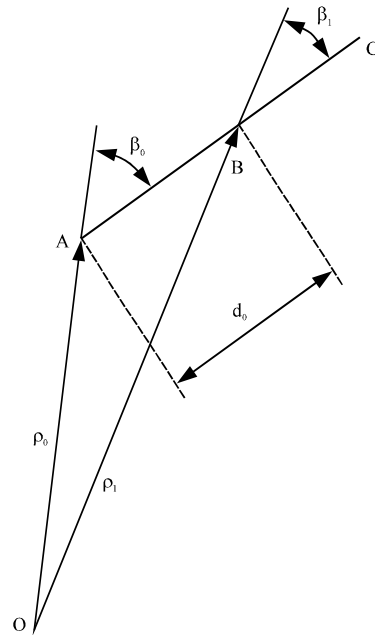

Fig. 5: Scheme to determine the angular size of the booster assembly

Where:

ω = Speed (sec)

μ = The coefficient of friction of the material on the surface of the booster blades

β_1 = The angle formed by the direction (OB) with the booster blade (Fig. 4)

ρ_1 = Distance from the rotor axis to the point B which is given by:

$$\rho_1 = \rho_0 \sqrt{1 + \frac{2d_0}{\rho_0} \cos \beta_0 + \left(\frac{d_0}{\rho_0}\right)^2} \quad (8)$$

Likewise we find that the time required for the passage of material particles path from point A to point C (path length L):

$$t_2 = \frac{L}{v(\rho_0)} \quad (9)$$

Where in the value $v(\rho_0)$ which is determined from the relationship:

$$v(\rho_0) = \omega \rho_0 \frac{\cos \beta_0 - \mu \sin \beta_0}{2\mu} \quad (10)$$

Then, the period of time between the gathering of the blade with a boost initial and final portions of the material will be determined by the relation:

$$\Delta t = t_2 - t_1 = \frac{L}{v(\rho_0)} - \frac{L - d_0}{v(\rho_1)} \tag{11}$$

$$= L \left(\frac{1}{v(\rho_0)} - \frac{1}{v(\rho_1)} \right) + \frac{d_0}{v(\rho_1)}$$

On the other hand, this interval can be determined by the rotation angle φ and the rotational frequency ω of the rotor:

$$\Delta t = \frac{\varphi_2 - \varphi_1}{\omega} = \frac{\Delta j}{\omega} \tag{12}$$

On the basis of Eq. 11 and 12 we find that:

$$\Delta \varphi = \frac{2\mu}{\rho_0} (L_* + d_*) \tag{13}$$

where we use the following notation:

$$L_* = L \left(\frac{1}{\cos\beta_0 - \mu\sin\beta_0} - \frac{1}{(\cos\beta_1 - \mu\sin\beta_1) \sqrt{1 + \frac{2d_0}{\rho_0} \cos\beta_0 + \left(\frac{d_0}{\rho_0}\right)^2}} \right) \tag{14}$$

And:

$$d_* = \frac{d_0}{(\cos\beta_1 - \mu\sin\beta_1) \sqrt{1 + 2\frac{d_0}{\rho_0} \cos\beta_0 + \left(\frac{d_0}{\rho_0}\right)^2}} \tag{15}$$

Equations 14 and 15 can be simplified to a number of the following assumptions: The ratio d_0/ρ_0 is a small value, then up to a first order, we find that:

$$L_* \cong L \left(\frac{1}{\cos\beta_0 - \mu\sin\beta_0} - \frac{1 - \frac{d_0}{\rho_0} \cos\beta_0}{\cos\beta_1 - \mu\sin\beta_1} \right) \tag{16}$$

And:

$$d_* \cong \frac{d_0 \left(1 - \frac{d_0}{\rho_0} \cos\beta_0 \right)}{\cos\beta_1 - \mu\sin\beta_1} \tag{17}$$

We assume that the accelerating rotor blade has a radial arrangement whereas in (Eq. 16 and 17) must be set $\beta_0 = \beta_1 = 0$ and the Eq. 14 and 15 will eventually look like this:

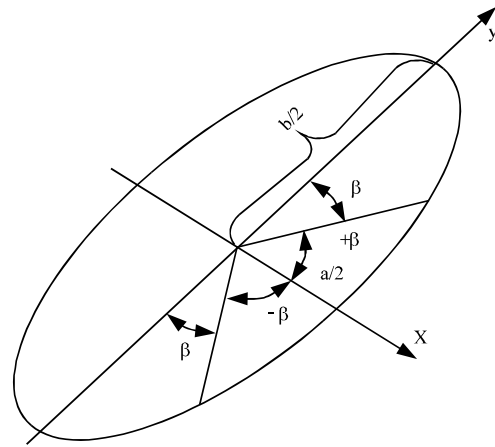

Fig. 6: Scheme to the calculation of the length of the booster blades in an arc of an ellipse

$$L_* = L \left(1 - \frac{1}{\left(1 + \frac{d_0}{\rho_0} \right)} \right) = \frac{Ld_0}{\rho_0 + d_0} \tag{18}$$

$$d_* = \frac{d_0}{1 + \frac{d_0}{\rho_0}} = \frac{d_0\rho_0}{\rho_0 + d_0} \tag{19}$$

and Eq. 16 and 17 in this case takes the following form:

$$L_* \cong \frac{Ld_0}{\rho_0} \tag{20}$$

$$d_* = d_0 \left(1 - \frac{d_0}{\rho_0} \right) \tag{21}$$

Thus, the dependence (Eq. 13-21) determine the angular size of the tangential channel 2 (Fig. 6), the unit of grinding and classification of materials. The calculation of the length of the booster blades in an arc of an ellipse. Arc length booster vanes determined from Eq. 22:

$$L = \int \sqrt{dx^2 + dy^2} \tag{22}$$

Where:

$$x = \rho \cos\varphi, \quad y = \rho \sin\varphi$$

$$(dx)^2 = (d\rho_1 \cos\varphi - \rho \sin\varphi d\varphi)^2$$

$$= \cos^2\varphi (d\rho)^2 - 2\rho \sin\varphi \cos\varphi d\rho d\varphi + \rho^2 \sin^2\varphi d\varphi^2$$

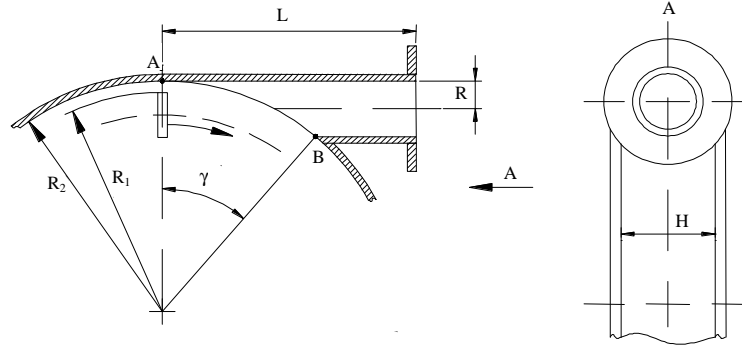

Fig. 7: Design scheme to determine the flow rate of the finished product in a cell disintegrator grinding mill type

$$(dy)^2 = (\sin \varphi d\rho + \rho \cos \varphi d\varphi)^2 \quad \left(\frac{d\rho}{d\varphi}\right)^2 = \frac{a^2 \varepsilon^4 \sin^2 2\varphi}{(1 - \varepsilon^2 \sin^2 \varphi)^3} \quad (26)$$

$$= \sin^2 \varphi (d\rho)^2 + 2\rho \sin \varphi \cos \varphi d\rho d\varphi + \rho^2 \cos^2 \varphi d\varphi^2$$

Thus:

$$(dx)^2 + (dy)^2 = (d\rho)^2 + \rho^2 (d\varphi)^2 = \rho^2 + \left(\frac{d\rho}{d\varphi}\right)^2 d\varphi^2 \quad \rho^2 + \left(\frac{d\rho}{d\varphi}\right)^2 = \frac{a^2}{1 - \varepsilon^2 \sin^2 \varphi} + \frac{a^2 \varepsilon^4 \sin^2 2\varphi}{(1 - \varepsilon^2 \sin^2 \varphi)^3}$$

$$L = \int_a^b \sqrt{\rho^2 + \left(\frac{d\rho}{d\varphi}\right)^2} d\varphi \quad (23)$$

$$= \frac{a^2}{(1 - \varepsilon^2 \sin^2 \varphi)^3} ((1 - \varepsilon^2 \sin^2 \varphi)^2 + \varepsilon^4 \sin^2 2\varphi)$$

$$= \frac{a^2}{(1 - \varepsilon^2 \sin^2 \varphi)^3} (1 - 2\varepsilon^2(1 - 2\varepsilon^2)\sin^2 \varphi - 3\varepsilon^4 \sin^4 \varphi) \quad (27)$$

The length of the blade in the form of accelerating the arc of the ellipse takes the final form:

$$x^2 = \rho^2 \cos^2 \varphi$$

$$y^2 = \rho^2 \sin^2 \varphi$$

$$\frac{\rho^2 \cos^2 \varphi}{a^2} + \frac{\rho^2 \sin^2 \varphi}{b^2} = 1$$

$$L = a \int_{\varphi_1}^{\varphi_2} \sqrt{\frac{1 - 2\varepsilon^2(1 - 2\varepsilon^2)\sin^2 \varphi - 3\varepsilon^4 \sin^4 \varphi}{(1 - \varepsilon^2 \sin^2 \varphi)^3}} d\varphi \quad (28)$$

Hence:

$$\rho^2(b^2 - (b^2 - a^2)\sin^2 \varphi) = a^2 b^2$$

or assume that $b > a$, consequently $(a/b) < 1$ then:

$$\rho^2 \left(1 - \left(1 - \frac{a^2}{b^2}\right) \sin^2 \varphi\right) = a^2 \quad (24)$$

$$\varepsilon^2 = 1 - \frac{a^2}{b^2} > 0$$

$$\rho^2 = \frac{a^2}{1 - \varepsilon^2 \sin^2 \varphi}$$

$$\frac{d\rho}{d\varphi} = \frac{a^2 \varepsilon^2 \sin \varphi \cos \varphi}{(1 - \varepsilon^2 \sin^2 \varphi)^2 \sqrt{1 - \varepsilon^2 \sin^2 \varphi}} \quad (25)$$

$$= \frac{a \varepsilon^2 \sin 2\varphi}{(1 - \varepsilon^2 \sin^2 \varphi)^{3/2}}$$

Let us consider the problem associated with the definition of the exit condition of the material particles in the discharge tube assembly with a central loading chamber grinding mill disintegrator type (Fig. 7).

Consider the relationship between structural and technological parameters of the mill type disintegrator in the design of the discharge pipe. According to the calculation scheme in Fig. 7, we find that the arc length l (in scheme AB) is equal to (Semikopenko *et al.*, 2011):

$$l = R_2 \gamma \quad (29)$$

Where:

R_2 = The inner radius of the camera body grinding mill disintegrator type

γ = The angular size of the discharge opening is given in radians

Assuming that when approaching the discharge orifice, all particles of the material move in a circular arc of

radius R_2 at a rate equal to the frequency of rotation ω of the last series of work items, if t-time of the particle in an arc l , based on the foregoing it is possible to write:

$$R_2\gamma = \frac{at^2}{2} \quad (30)$$

Where:

$$a = \omega r \quad (31)$$

where, r-distance from the axis of rotation of the rotor to the considered path. On the basis of Eq. 30 with Eq. 31, we find that:

$$t = \sqrt{\frac{2R_2\gamma}{\omega^2 r}} \quad (32)$$

In order the particle of material left disintegrator mill grinding chamber through the discharge opening type with angular dimension to that for the time (Eq. 32) we need the particle material in the radial direction length was greater than or equal to half the diameter of the particulate material. Based on the above we can write the following expression:

$$\frac{d}{2} < v_r \quad (33)$$

where, v_r -velocity of particulate material in a radial direction. The relation of communicational speed of the material particles in a given volume of particles has a diameter d as a function of the distance r to the center of rotation can be determined from the following relationship:

$$\frac{mv_r^2}{r} = 3\pi\mu dv_r \quad (34)$$

where, μ -the coefficient of dynamic viscosity of air, equal to $1.84000001 \cdot 10^{-6}$ Pa·s. (Tuft *et al.*, 1982). Equation 31 is a centrifugal force equal resistance to movement of the particle in the radial direction. On the basis of (Eq. 31) assumes that the drag force is the Stokes character. According to Eq. 31 we find that:

$$v_r = \frac{18\mu r}{\rho d^2} \quad (35)$$

where, ρ -the density of the particle material. According to Eq. 35 it is assumed that the particle material to be ground is spherical in shape. In view of Eq. 32, 35 and 33 can be reduced to the following form:

$$\frac{d}{2} \leq \frac{18\mu r}{\rho d^2} \times \frac{1}{\omega_r} \sqrt{\frac{2R_2\gamma}{r}} \quad (36)$$

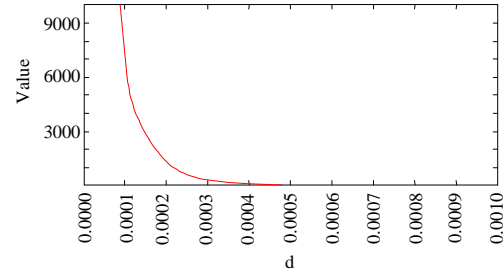

Fig. 8: Dependence ω_{max} on the diameter d of the particle material with $R_2 = 0.2$ m; $\rho = 200$ kg/m³

then to move the particles of the material with a circular path of radius R_2 to $R_2+d/2$ trajectory on the basis of Eq. 36 we find:

$$\omega \leq \frac{36\mu(R_2 + \frac{d}{2})}{\rho d^3} \sqrt{\frac{2R_2\gamma}{R_2 + \frac{d}{2}}} \quad (37)$$

It is easy to see that Eq. 37 can be reduced to the following form:

$$\omega \leq \frac{36\mu R_2 \left(1 + \frac{d}{2R_2}\right)}{\rho d^3} \sqrt{\frac{2\gamma}{1 + \frac{d}{2R_2}}} \quad (38)$$

Equation 38 can be simplified if we consider that the ratio is a small value $d/2R_2$ then the value of considering $d/2R_2$ the small quantity of the first order relation (Eq. 38) is provided with an accuracy of the first order to the form:

$$\omega \leq \frac{36\mu R_2}{\rho d^3} \sqrt{2\gamma} \left(1 + \frac{d}{4R_2}\right) \quad (39)$$

Equation 39 can be conveniently written in the form:

$$\omega \leq \omega_{max} \quad (40)$$

whereas, ω_{max} introduced the following notation:

$$\omega_{max} = \frac{36\mu R_2}{\rho d^3} \sqrt{2\gamma} \left(1 + \frac{d}{4R_2}\right) \quad (41)$$

Thus, from Eq. 40 to the particle material left disintegrator mill grinding chamber requires that the speed of the material particles satisfy the relation (Eq. 40). Depending of the nature of the ω_{max} diameter of the particle material can be from Fig. 8.

DISCUSSION

The grinding process in the production of building materials is one of the most energy-intensive processes. So, the impact on the feedstock for energy-scan mode in conjunction with the withdrawal from the area of particle size reduction, corresponding to the finished product, it is very important. The most complete this process can be accomplished by combining the processes of grinding and classification within a single unit, observing the principle of staging.

In this study, the design procedure of the main parameters of the machine grinding and classifying materials.

CONCLUSION

The method of calculation of geometrical parameters in the major sites of particle acceleration and unloading of the machine grinding and classification of materials, taking into account the structural and technological features were developed.

REFERENCES

Bogorodskiy, A.V., 1982. Investigation of the grinding process of bulk materials in mills Impact. Proceedings of the 4th All Union Conference on the Mechanics of Granular Materials, (MGM'82), Odessa, pp: 190.

Giersiepen, G., 1973. Maschinen und apparate fur die feinstzerkleinerung. Aufbereitungs Technik, 14: 277-284.

Hint, I.A., 1962. Fundamental Production of Silicalcite Products. Strojizdat, Moscow, Pages: 602.

Poliad, M. and F. Cochet, 1990. A look at internet grinding shop. World Cement, 9: 395-399.

Semikopenko, I.A., V.P. Voronov, P.P. Penzev, S.V. Vyalykh and S.I. Gordeev, 2011. Determining the exit condition of the material particles in the discharge pipe grinding chamber disintegrator. Bull. BSTU, 2: 90-91.

Tuft, N.V., V.N. Blinichev, S.P. Bobkov and A.V. Piskunov, 1982. Method of calculation of the air flow in a centrifugal impact mill. Chem. Chem. Technol., 2: 230-232.

Voronov, V.P., I.A. Semikopenko and P.P. Penzev, 2008. Theoretical studies of the velocity of the particles of the material along the surface of the impactor type disintegrator mill. Proc. Univ., 12: 93-96.

Voronov, V.P., I.A. Semikopenko and P.P. Penzev, 2009. Pneumatic mechanical grinding-classification complex. Proc. Univ. Build., 9: 91-99.