

Metal Cutting Tool Position Control using Static Output Feedback and Full State Feedback Controllers

¹Mustefa Jibril, ¹Messay Tadese and ²Roman Jirma

¹*School of Electrical and Computer Engineering,*

²*School of Industrial and Mechanical Engineering, Dire Dawa Institute of Technology, Dire Dawa, Ethiopia*

Key words: Metal cutting machine, static output feedback, full state feedback H₂ controllers

Corresponding Author:

Mustefa Jibril

School of Electrical and Computer Engineering, Dire Dawa Institute of Technology, Dire Dawa, Ethiopia

Page No.: 18-25

Volume: 14, Issue 1, 2021

ISSN: 1997-5422

International Journal of Systems Signal Control and Engineering Application

Copy Right: Medwell Publications

Abstract: In this study, a metal cutting machine position control have been designed and simulated using MATLAB/Simulink Toolbox successfully. The open loop response of the system analysis shows that the system needs performance improvement. Static output feedback and full state feedback H₂ controllers have been used to increase the performance of the system. Comparison of the metal cutting machine position using static output feedback and full state feedback H₂ controllers have been done to track a set point position using step and sine wave input signals and a promising results have been analyzed.

INTRODUCTION

A metal cutting machine or cutter tool is any tool that is used to separate some metallic material from the work piece by means of cutting. Cutting may be accomplished by single-point or multipoint tools. Single point tools are used in turning, shaping, planing and similar operations and remove material by means of one cutting edge. Cutting tool materials must be harder than the material which is to be cut and the tool blade must be in accurate position. The coordinate position of the blade might be 1D (dimension), 2D and 3D and it must be able to withstand the disturbances that arise for example from the force generated in the metal-cutting process^[1,2]. Also, the tool must have a specific geometry with clearance angles designed, so that, the cutting edge can contact the work piece without the rest of the tool dragging on the work piece surface.

MATERIALS AND METHODS

Mathematical modeling: A solenoid system is fed with an electrical voltage. The force exerted by the solenoid system is proportional to the current. This force controls the hydraulic actuator input. The hydraulic actuator system is fed with fluid from a constant pressure source in which the compressibility of the fluid is negligible^[3]. An input displacement x moves the control valve; thus fluid passes in to the upper part of the cylinder and the piston is forced to move horizontally. A low power displacement of $x(t)$ causes a large high power displacement $y(t)$. The output displacement moves the cutter blade. The system layout is shown in Fig. 1. The solenoid coil circuit equation becomes:

$$e(t) = Ri(t) + L \frac{di(t)}{dt} \quad (1)$$

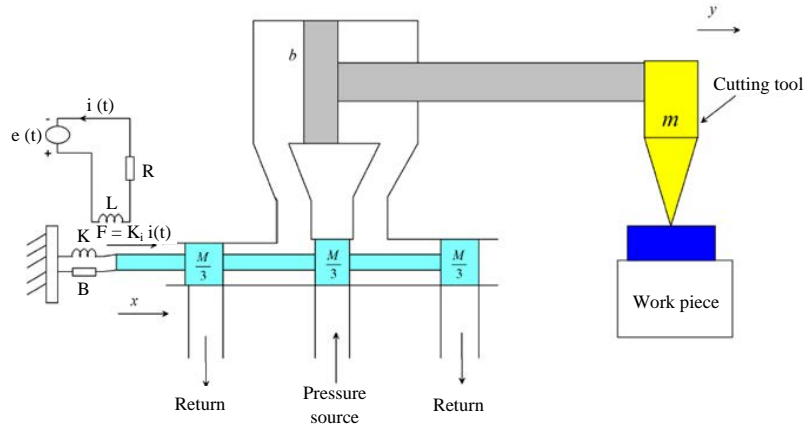

Fig. 1: Metal cutter machine

Taking Laplace transform and arranging the transfer function between the input voltage and the output current become:

$$\frac{I(s)}{E(s)} = \frac{1}{Ls + R} \quad (2)$$

The force on the shaft is proportional to the current $i(t)$, so that:

$$F = K_i i(t) \quad (3)$$

Taking Laplace transform and arranging the transfer function between the input current and the output force become:

$$\frac{F(s)}{I(s)} = K_i s \quad (4)$$

The force balance equation of the control valve becomes:

$$M \frac{d^2 x}{dt^2} + B \frac{dx}{dt} + Kx = F \quad (5)$$

Taking Laplace transform and arranging the transfer function between the input force and the output displacement become:

$$\frac{X(s)}{F(s)} = \frac{1}{Ms^2 + Bs + K} \quad (6)$$

The flow rate of the fluid Q is related to the input displacement $x(t)$ and the differential pressure across the piston will be:

$$Q = g(x, P) \quad (7)$$

Using Taylor series linearization technique we have:

$$Q = \left(\frac{\partial g}{\partial x} \right)_{x_0, P_0} x + \left(\frac{\partial g}{\partial P} \right)_{x_0, P_0} P = k_x x + k_p P \quad (8)$$

where, $g = g(x, P)$ and (x_0, P_0) is the operating point, the piston developed a force which is the area of the piston A multiplied by the pressure P . The applied force to the mass become:

$$AP = m \frac{d^2 y}{dt^2} + b \frac{dy}{dt} \quad (9)$$

Where:

m = Mass of the cutter

b = Damping coefficient of the piston

Substituting (Eq. 8) in to (Eq. 9) yields:

$$\frac{A}{k_p} (k_x x - Q) = m \frac{d^2 y}{dt^2} + b \frac{dy}{dt} \quad (10)$$

The fluid flow is proportional to the to the piston movement as:

$$Q = K_q y \quad (11)$$

Substituting (Eq. 11) in to (Eq. 10) and rearranging yields:

$$\frac{Ak_x}{k_p} x = m \frac{d^2 y}{dt^2} + b \frac{dy}{dt} + \frac{AK_q}{k_p} y \quad (12)$$

Therefore, the transfer function between the output displacement and input displacement will be:

Table 1: Metal cutting machine parameters

Parameters	Symbols	Values
Resistance	R	100 Ω
Inductance	L	13 H
Spring stiffness attached to control valve	K	12 N/m
Damping coefficient attached to control valve	B	3.3 N sec/m
Mass of the control valve	M	1.4 kg
Force current constant	K_i	18 N/A
Fluid piston constant	K_q	0.25
Mass of the cutter blade	m	3 kg
Area of the piston	A	0.25 m ²
Damping coefficient of the piston	b	6.3 N-sec/m
Displacement constant	k_x	8
Pressure constant	k_p	4

$$\frac{Y(s)}{X(s)} = \frac{\left(\frac{Ak_x}{k_p}\right)}{\left(ms^2 + bs + \frac{AK_q}{k_p}\right)} \quad (13)$$

Therefore, the overall transfer function between the input voltage and the output cutter blade position can be obtained by multiplying (Eq. 2, 4, 6 and 13):

$$G(s) = \frac{Y(s)}{E(s)} = \frac{K_i K_1}{(Ls + R)(Ms^2 + Bs + K)(ms^2 + bs + K_2)}$$

Where:

$$K_1 = \left(\frac{Ak_x}{k_p}\right)$$

$$K_2 = \left(\frac{AK_q}{k_p}\right)$$

The metal cutting machine parameters is shown in Table 1. The transfer function of the system then becomes:

$$G(s) = \frac{Y(s)}{E(s)} = \frac{9}{54.6s^5 + 663.4s^4 + 2725s^3 + 7818s^2 + 10630s + 7584}$$

The state space representation of the system becomes:

$$\dot{x} = \begin{pmatrix} -12.15 & -6.239 & -4.474 & -3.042 & -1.085 \\ 8 & 0 & 0 & 0 & 0 \\ 0 & 4 & 0 & 0 & 0 \\ 0 & 0 & 2 & 0 & 0 \\ 0 & 0 & 0 & 2 & 0 \end{pmatrix} x +$$

$$y = \begin{pmatrix} 0.03125 \\ 0 \\ 0 \\ 0 \\ 0 \end{pmatrix} u$$

$$y = (0 \ 0 \ 0 \ 0 \ 0.04121)x$$

The proposed controllers design

Static output feedback controller design: Consider a linear time invariant system:

$$\dot{\delta x}(t) = Ax(t) + Bu(t) \quad y(t) = Cx(t) \quad (14)$$

Where:

$$\delta x(t) = \dot{x}(t)$$

$x(t) \in \mathbb{R}^n$, $u(t) \in \mathbb{R}^m$, $y(t) \in \mathbb{R}^l$ are state, control and output vectors, respectively; A, B, C are constant matrices of appropriate dimensions. The feedback control law is considered in the form:

$$u(t) = Fy(t) = FCx(t) = Kx(t) \quad (15)$$

where, F is a static output feedback controller gain matrix. The closed-loop system is then:

$$\delta \dot{x}(t) = A_c x(t) \quad (16)$$

Where:

$$A_c = A + BFC$$

The block diagram of the cutter system with static output feedback controller gain matrix is shown in Fig. 2.

It is well known that the fixed order dynamic output feedback control design problem is a special case of the static output feedback problem, since, the closed-loop system for the fixed order case has exactly the same structure as the static case with appropriately augmented system matrices^[4, 5]. Therefore, study of static output feedback problem includes more general scope of control problems. To assess the performance quality a quadratic cost function known from LQ theory is often used. However, in practice the response rate or overshoot are often limited. Therefore, we include into the LQR cost function the additional derivative term for state variable to open the possibility to damp the oscillations and limit the response rate:

$$J_c = \int_0^{\infty} [x(t)^T Qx(t) + u(t)^T Ru(t) + \delta x(t)^T S \delta x(t)] dt \quad (17)$$

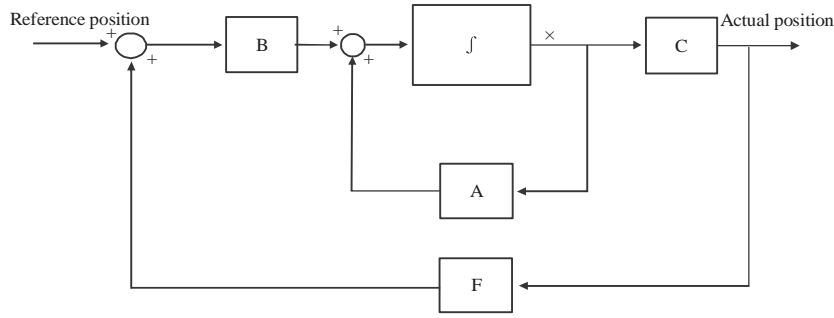

Fig. 2: Block diagram of the cutter system with static output feedback controller gain matrix

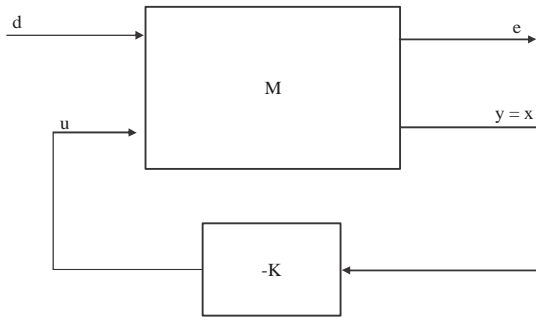

Fig. 3: A full state feedback system

For this system the static output feedback controller gain matrix becomes:

$$F = [3.32]$$

Then the feedback control law is becoming:

$$u(t) = [3.32]y(t) = (0 \ 0 \ 0 \ 0 \ 0.1368172)x(t)$$

$$K = (0 \ 0 \ 0 \ 0 \ 0.1368172)$$

Full state feedback H2 controller design: Consider (Fig. 3) and assume that:

$$M = \begin{bmatrix} A & B_1 & B_2 \\ C_1 & 0 & D_{12} \\ I & 0 & 0 \end{bmatrix} \quad (18)$$

From (Eq. 18):

$$\dot{x} = Ax + B_1d(t) + B_2u(t) \quad (19)$$

$$e(t) = C_1x(t) + D_{12}u(t) \quad (20)$$

$$y(t) = x(t) \quad (21)$$

Assuming that $d(t)$ is the white noise vector with unit intensity:

$$\|T_{ed}(s)\|_{H_2}^2 = E(e^T(t)e(t)) \quad (22)$$

Where:

$$e^T e = x^T C_1^T C_1 x + 2x^T C_1^T D_{12} u + u^T D_{12}^T D_{12} u \quad (23)$$

With (Eq. 19 and 22), the minimization of $\|T_{ed}(s)\|_{H_2}$ is equivalent to the solution of the stochastic regulator problem. Setting:

$$Q_f = C_1^T C_1, \quad N_f = C_1^T D_{12} \quad \text{and} \quad R_f = D_{12}^T D_{12} \quad (24)$$

The optimal state feedback law is given by:

$$u = -Kx \quad (25)$$

where:

$$K = R_f^{-1} (PB_2 + N_f)^T \quad (26)$$

And:

$$P(A - B_2 R_f^{-1} N_f^T) + (A - B_2 R_f^{-1} N_f^T)^T P - P B_2 R_f^{-1} B_2^T P + Q_f - N_f R_f^{-1} N_f^T = 0 \quad (27)$$

It should be noted that the gain K is independent of the matrix B_1 . For this system the full state feedback gain matrix becomes:

$$K = (-1.3453 \quad 0.2574 \quad 1.3754 \quad -0.3628 \quad 0.7077)$$

RESULTS AND DISCUSSION

Here, in this study, the investigation of the open loop response and the closed loop response with the proposed controller for the comparison of the system have been done.

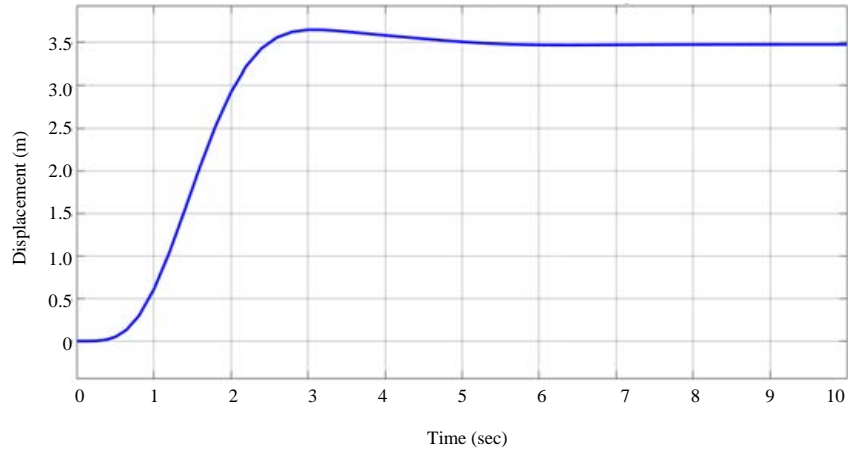

Fig. 4: Open loop response; open loop response blade position response to 1400 V voltage input

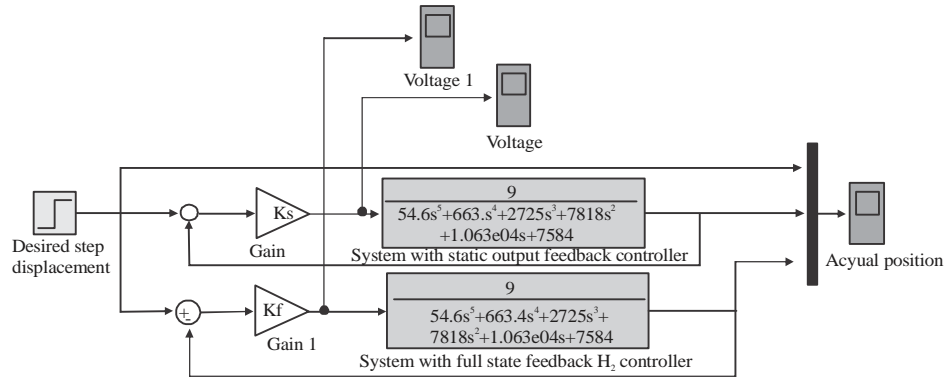

Fig. 5: Simulink model of the cutting machine using static output feedback and full state feedback H₂ controllers using step input desired position signal

Table 2: Step response data

Performance data	Full state feedback H ₂ controller	Static output feedback
Rise time	1.8 sec	1.8 sec
Per. overshoot	17%	34.2%
Settling time	8 sec	12 sec
Peak value	4.1 m	4.7 m

Open loop response of the cutter machine: The open loop response of the system for a 1400 V input simulation is shown in Fig. 4. The open loop response of the machine shows that the system input is a high voltage and the system needs improvement.

Comparison of the cutting machine using static output feedback and full state feedback H₂ controllers using step input desired position signal: The Simulink Model of the cutting machine using static output feedback and full state feedback H₂ controllers using step input desired position signal is shown in Fig. 5.

The simulation result of the comparison with the input voltage to the cutting machine using

static output feedback and full state feedback H₂ controllers are shown in Fig. 6-8, respectively^[6, 7]. The input voltages of the cutting machine system with the proposed controllers shows improvement in reducing the voltage amplitude but the system with full state feedback H₂ controller shows better improvement. The data of the rise time, percentage overshoot, settling time and peak value is shown in Table 2.

As Table 2 shows that the cutting machine system with full state feedback H₂ controller improves the performance of the system by minimizing the percentage overshoot and settling time.

Comparison of the cutting machine using static output feedback and full state feedback H₂ controllers using sine wave input desired position signal: The Simulink model of the cutting machine using static output feedback and full state feedback H₂ controllers using sine wave input desired position signal is shown in Fig. 9.

Figure 9 Simulink Model of the cutting machine using static output feedback and full state feedback H₂

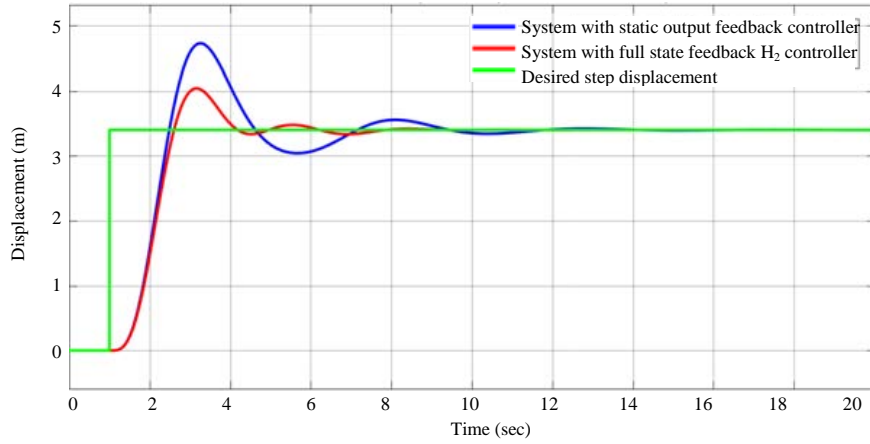

Fig. 6: Step response of the comparison; Actual blade position response to step desired blade position input

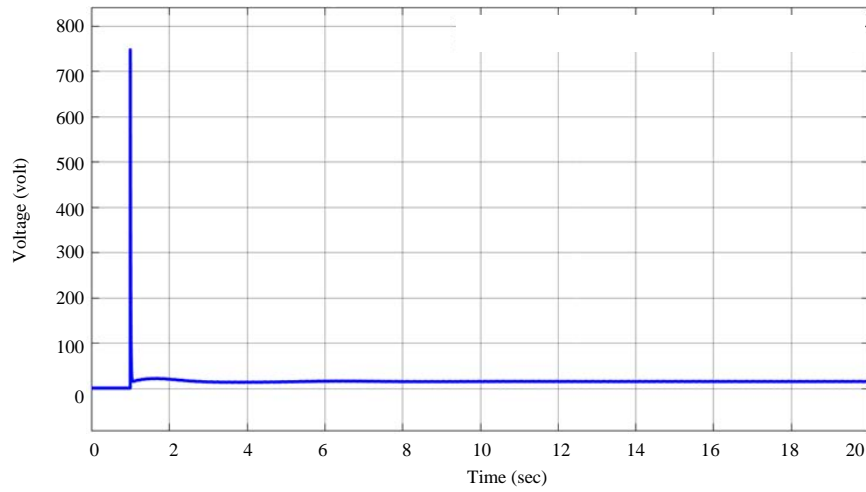

Fig. 7: Input voltage to the system with static output feedback controller

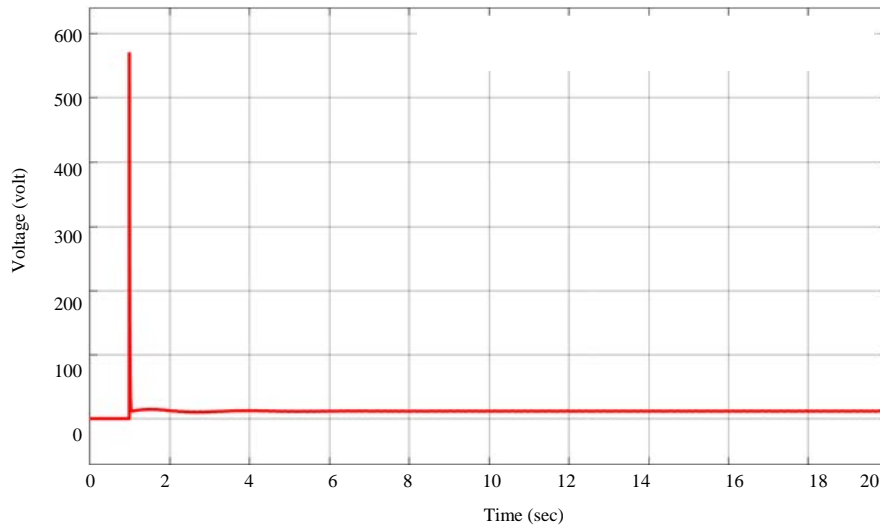

Fig. 8: Input voltage to the system with full state feedback controller

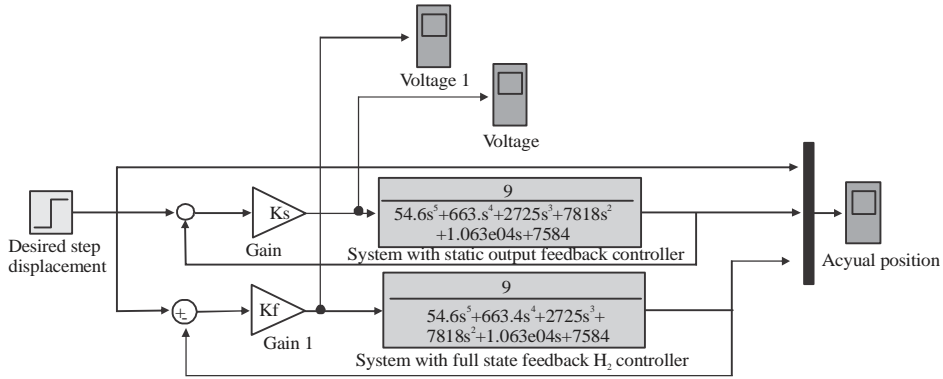

Fig. 9: Simulink model of the cutting machine using static output feedback and full state feedback H_2 controllers using sine wave input desired position signal

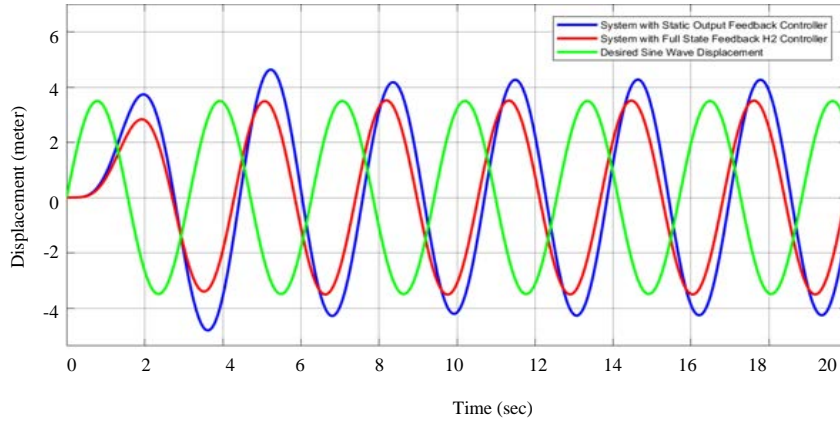

Fig. 10: Sine wave response of the comparison; Actual blade response to sine wave desired blade position input

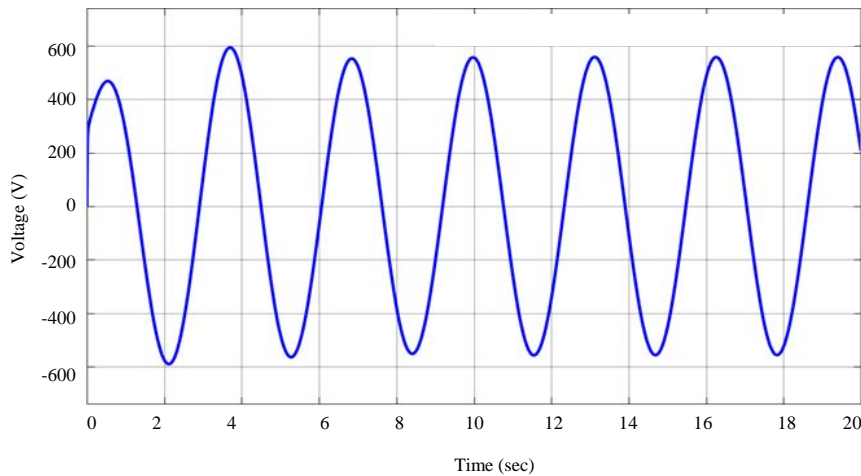

Fig. 11: Input voltage to the system with static output feedback controller

controllers using sine wave input desired position signal. The simulation result of the comparison with the input voltage to the cutting machine

using static output feedback and full state feedback H_2 controllers are shown in Fig. 10-12, respectively.

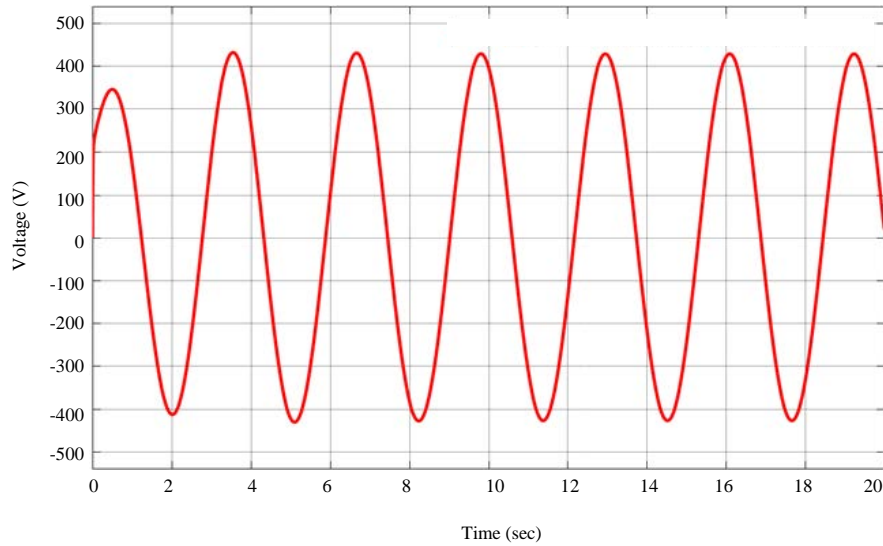

Fig. 12: Input voltage to the system with full state feedback controller

The input voltages of the cutting machine system with the proposed controllers shows improvement in reducing the voltage amplitude but the system with full state feedback H_2 controller shows better improvement.

CONCLUSION

In this study, the design and position control of a metal cutting machine have been done using static output feedback and full state feedback H_2 controllers. The open loop response of the system analysis shows that for the system cutting position of 3.4 m, 1400 V input is needed which is a high voltage, so, the system needs performance improvement. Comparison of the metal cutting machine position using static output feedback and full state feedback H_2 controllers have been done to track a set point position using step and sine wave input signals. Both responses show that the cutting machine system with full state feedback H_2 controller improves the performance of the system by minimizing the percentage overshoot and settling time.

REFERENCES

Alabdullah, M., A. Polishetty and G. Littlefair, 2016. Impacts of wear and geometry response of the cutting tool on machinability of super austenitic stainless steel. *Int. J. Manufacturing Eng.*, Vol. 2016, 10.1155/2016/7213148.

01. Chen, Y.L., W. Gao, B.F. Ju, Y. Shimizu and S. Ito, 2014. A measurement method of cutting tool position for relay fabrication of microstructured surface. *Meas. Sci. Technol.*, Vol. 25, No. 6.
02. Chen, Y., J. Wang and M. Chen, 2019. Enhancing the machining performance by cutting tool surface modifications: A focused review. *Mach. Sci. Technol.*, 23: 477-509.
03. O'Hara, J. and F. Fang, 2019. Advances in micro cutting tool design and fabrication. *Int. J. Extreme Manufacturing*, Vol. 1, No. 3.
04. Lin, C.Y. and S.S. Yeh, 2020. Integration of cutting force control and chatter suppression control into automatic cutting feed adjustment system design. *Mach. Sci. Technol.*, 24: 65-95.
05. Dimla Sr, D.E. and P.M. Lister, 2000. On-line metal cutting tool condition monitoring.: I: Force and vibration analyses. *Int. J. Mach. Tools Manufacture*, 40: 739-768.
06. Han, Z., H. Jin, Y. Fu and H. Fu, 2017. Cutting deflection control of the blade based on real-time feedrate scheduling in open modular architecture CNC system. *Int. J. Adv. Manufacturing Technol.*, 90: 2567-2579.