

## Design Method of High-Frequency OTA-C Filters in Speech Communication System

Farouq Al-Taweel

Department of Electrical Engineering, Al-Balqa Applied University, Jordan

**Abstract:** This application describes the optimization procedure for design of high frequency OTA-C filters, used in dialogic processing applications. The objective function is set-up so as determine, the design parameters that satisfy the required special fiction with the least possible influences of the parasitic poles. These poles are introduced as result of the excess phase of the finite band or any selected band width.

**Key words:** High-frequency, speech, communication, filters, processing, Jordan

### INTRODUCTION

The Operational Transconductance Amplifier (OTA) as an integrated circuit and it has since gained wide acceptance as a gettable, gain controlled building block for instrumentation amplifiers from the noun power range to high current and high speed compurgators and as an active element in conventional filters applications (Al-Taweel, 2004; Kim and Geiger, 1988). High frequency filters based upon conventional op-amps are recognized as impractical due to both the high frequency VCF limitation and inability to practically and accurately control the passive components values (Kim and Geiger, 1988).

OTAs offers some advantages of extended frequency range, integration facility as only active device and capacitors are necessary, a reduction in component count and simpler design equations, considerable programmability by being able to vary transconductance  $g_m$  over several decades and low passive sensitivities of the OTA filter configuration. The ideal OTA is a Differential-input Voltage-controlled Current Source (DVCCS). Its representation is shown in Fig. 1 and its output current  $I_o$  may be expressed by the following equation:

$$I_o = g_m (V_1 - V_2) \quad (1)$$

where,  $g_m$  is the transconductance can be controlled externally by the current  $I_b$ ,  $V_1$  and  $V_2$  are inverting and non-inverting input voltage with reference to ground. The design of most active filters is usually carried out with the assumption that ideal active devices are being used. This assumption may lead to severs deterioration of network performance. The dominant poles and zeros of networks will be shifted thus altering the frequency response or the gain at frequency of importance. Therefore, the non-ideal

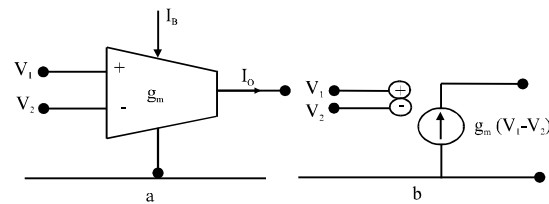

Fig. 1: Ideal OTA; a) Symbol and b) Equivalent circuit

behavior of the OTA devices should be considered and must be accounted for the design stages (Bowron and Dahir, 1989; Al-Taweel, 2004). Serial OTA-C biquadratic structures have been reported with different number of OTAs as well as degrees of freedom (Kim and Geiger, 1988). The maximal frequencies, however were limited to the lower megahertz range (Linares-Barranco *et al.*, 1989). In some circumstances, their true frequency response can deviate substantially from what was designed for assuming ideal components. These deviations are mainly due to the non-idealities of OTA.

### THE OTA MODEL

One analytically tractable method is to assume a time delay  $\tau$  through each OTA. For the frequencies much lower than  $\tau^{-1}$  can be approximated by the first two terms of its Taylor expression (Rodriguez-Vazquez *et al.*, 1990).

$$g_m(s) = g_{m0} e^{-s\tau} \approx g_{m0} (1 - s\tau) \quad (2)$$

where,  $g_{m0}$  is the dc value of  $g_m$ , thus a model consisting of a single zero on the right-half of the complex frequency s-plane is obtained. This model provides the same degree of approximation for the phase shift as the more convenetial model consisting of a singal left-half plane or:

$$g_m(s) = \frac{g_{mo}}{1 + s/w_0} \quad (3)$$

where,  $w_0 = 1/\tau$  is an effective pole characterizing several high frequency internal mirror poles. Or may be approximated by two-pole model for approximations entering the megahertz rang with  $w_1$  and  $w_2$  are the first and second poles of the transconductance gain  $g_m$ , respectively:

$$g_m(s) = \frac{g_{mo}}{(1 + s/w_1)(1 + s/w_2)} \quad (4)$$

### OPTIMIZATION BASED DESIGN PROCEDURE

The modern approach of using optimization methods is appropriate to achieve a design that meets or exceeds certain requirements when classical synthesis approach fails to do so.

**Consideration of constraints:** One of the great advantages of computer-aided circuit optimization is that if the design problem has been properly formulated, feasible design can always be achieved assuming the initial design is feasible. Although, constraints in networks design can take a variety of forms, two types of constraints on the design parameters are considered in the present research. Upper and lower bounds on design parameters:

$$L_i < X_i < U_i \text{ for } i = 1, 2, \dots, n \quad (5)$$

Where:

$n$  = The number of design parameters such as capacitors or transconductance gain

$L_i$  and  $U_i$  = The lower and upper bounds of  $X_i$

The limits for capacitors may be taken from to PF t InF and for  $g_m$ , the range of  $1-10^4 \mu s$  of OTA type is chosen. Limiting the spread in the values of two similar design parameters within the specified values is usually required. Such constraint is important, especially is IC techniques and monolithic that OTA-C filters provide. Such constraint may be expressed as:

$$R_L < X_i/X_j < R_U \text{ for } i \neq j \quad (6)$$

where,  $R_L$  and  $R_U$  are the lower and upper ratio spread values, respectively. For the same component type, they are chosen to be 0.01 and 100, respectively to keep the spread of the component as low as possible, hence ensuring their close tracking with ambient variations.

### OPTIMIZATION METHOD USED

The first complex method which is a modification to the simplex method of Nelder and Mead is used to solve the constrained design problem. The basic move is to reflect the point having the greatest function value in the centroid of the simplex formed by the simplex formed by the remaining points. This method assumes a prior knowledge of the number of variables ( $n$ ), the number of constraints ( $m$ ), the lower and upper and bounds of parameter values ( $L_i, U_i$ ) and an initial feasible points  $X_i$  that satisfies all constraints mentioned earlier in accordance to the specific OTA based filters structure,  $n$  and  $m$  are produced automatically with the help of several programming procedures and functions that provide graphical and text aids for user interaction.

For filter specifications, the user can input the design requirements with interactive windows. In addition of  $f_0$  and  $Q$  factor, the designer can chosen the suitable transconductance model. If ideal OTAs are selected as to get an initial guess to design parameters that satisfy the filter specification ideally than the Coefficient Matching Techniques (CMT) is utilized to set up the objective function. The technique which was first proposed by Rodriguez-Vazquez *et al.* (1990) and Press (1992) has been shown to have many advantages compared with amplitude and phase matching techniques. The CMT can used here to set up the least square error objective function between the desired and the actual coefficients easily ant directly.

### THE OBJECTIVE FUNCTION

When the frequency dependent transconductance agains of the OTAs are expressed by one or two-pole models, the Denominator  $D(s)$  of the voltage transfer function will no longer be of second-order as in the case if ideal OTAs are assumed in structures such as those shown in Fig. 2a, b for example for circuit (a) in Fig. 2a if the transconductance gain of the two OTAs are approximated to the following sixth order polynomial:

$$D(s) = S^6 + 2B_s^5 + (2A+B2) S^4 + (+2AB)S^3 + (+A^2)S^2 + \frac{g_{m1}g_m + A^2}{C_1 C_2} \frac{g_{m2}A}{C_2} \frac{G_{m2}AB}{C_2} \quad (7)$$

where,  $A = w_1 w_2$ ,  $B = w_1 + w_2$  and  $w_1, w_2$  are as shown in Eq. 5. As a general form for a two-pole model, the Denominator  $D(s)$  will be:

$$D(s) = T_6 S^6 + T_5 S^5 + T_4 S^4 + T_3 S^3 + T_1 S + T_0 \quad (8)$$

where, the coefficient  $T_0$ - $T_6$  are function of the design parameters for the circuit under consideration.

$$D(s) = S^2 + S + w_0^2 (H_4S^4 + H_3S^3 + H_2S^2 + H_1S + 1) \quad (9)$$

where the first factor of Eq. 9 gives the desirable (ideal) frequency response (Press, 1992) and the second give the added parasitic pole effect due to  $g_m$  dependency on frequency.

By equating coefficients of the same powers of  $s$  of Eq. 8 (Rodriguez-Vazquez *et al.*, 1990) and (g) and assuming  $w_0 = 1$  for frequency normalization the following two equations are obtained after elimination of the coefficients  $H_1$ - $H_4$ :

$$T_6 (1 - d^2) + dT_6 + T_2 - dT_1 + T_0 (d^2 - 1) - T_4 = 0 \quad (10)$$

$$T_5 - dT_6 + dT_2 - T_1 (d^2 - 1) + T_0 (d^3 - 2d) - T_3 = 0 \quad (11)$$

where,  $d = 1/w$  in order to set up, the objective function these equations may be written in term of the error function  $E_1(X)$  and  $E_2(X)$  as in Press (1992):

$$E_1(X) = T_6 (1 - d^2) + dT_6 + T_2 - dT_1 + T_0 (d^2 - 1) - T_4 \quad (12)$$

$$E_2(X) = T_5 - dT_6 + dT_2 - T_1 (d^2 - 1) + T_0 (d^3 - 2d) - T_3 \quad (13)$$

The function is then formulated using least errors as:

$$\{E(X) = w (E_1(X))^2 + (E_2(X))^2\} \quad (14)$$

Where:

$w = A$  weighting factor  $w > 1$

$X =$  Defines the  $n$  design parameters, i.e.,  $X = (X_1, X_2, \dots, X_n)$

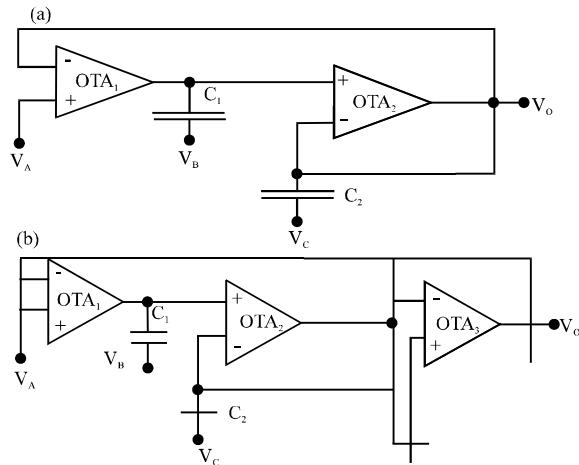

Fig. 2: Second-order filter structure

The objective function when one-pole model is used can be obtained easily with the same analysis. Nothing that  $D(s)$  will be of 4th order and setting  $H_4, H_3, T_6$  and  $T_5$  all to zero in Eq. 8 and 9, the required error function is obtained.

### EXPERIMENTAL RESULTS

The two-pole model of Fig. 3 is used to give 1st transconductance pole at 6.3 MHz, the 2nd and 4th pole at about 64 MHz for OTA type CA3280 used in the examples to be considered (Bowron and Dahir, 1989).

**Example 1:** For the 2nd order structure of circuit show in Fig. 2a, b it is required that  $f_0 = 4$  MHz and  $Q = 5$ , details of this design problem are shown in Table 1. It is clear that the filter is initially unstable before the application of the optimization process for the one- and two-pole model as expressed by the negative  $Q$  factors of the dominant-pole pair.

**Example 2:** The result of the optimum design for circuit in Fig. 3 shown in Table 2 for  $f_0 = 4$  MHz and  $Q = 9$  and equal values  $f_0$ , the transconductance gains  $g_{m1} = g_{m2} = g_3 = g_m$ .

**Example 3:** Circuit in Fig. 3 to satisfy  $f_0 = 200$  kHz,  $Q = 5$ , Table 3 shows the information on poles specification

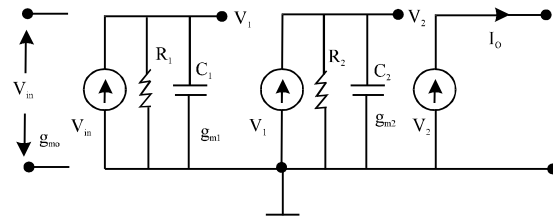

Fig. 3: Linear two-pole transconductance model

Table 1: Design problem example 1:  $f_0 = 4$  MHz,  $Q = 5$ ,  $g_{m1} \neq g_{m2}$

Factors of model	OTA model		
	Ideal	One-pole	Two-pole
$C_1$ (Farad)	7.9520 e-11	4.4985 e-10	4.7730 e-10
$C_2$ (Farad)	1.3690 e-9	2.7516 e-10	25395 e-10
$g_{m1}$ (S)	9.9927 e-3	9.9887 e-3	9.8224 e-3
$g_{m2}$ (S)	6.8815 e-3	9.9891 e-3	$Q = 1.35791$
			$f_0 = 3.3165$ MHz
Dominant poles*		$Q = 1.6942$	$Q = 4.9999$
		$f_0 = 3.20384$ MHz	$f_0 = 3.9999$ MHz
Dominant poles**	$Q = 4.9999$	$Q = 4.9999$	$Q = 0.6341$
	$f_0 = 3.9999$ MHz	$f_0 = 3.9999$ MHz	$f_0 = 63.3446$ MHz
Parasitic poles*	None	$Q = 0.6031$	$3.6311$ e-6
		$f_0 = 7.1168$ MHz	
Initial function value*	5.1999	4.9994 e-1	8.8288 e-8
Minimum function value**	9.8912 e-14	3.6694 e-14	551
Function evaluation	551	651	

Table 2: Optimum design for circuit example 2:  $f_0 = 4$  MHz,  $Q = 9$ ,  $g_{m1} = g_{m2} = g_{m3} = g_m$

Factors of model	OTA model		
	Ideal	One-pole	Two-pole
$C_1$ (Farad)	2.1918 e-11	1.5667 e-10	1.1529 e-10
$C_2$ (Farad)	1.7753 e-9	1.1703 e-10	6.9371 e-11
$g_m$ (S)	4.9578 e-3	3.8213 e-3	2.5906 e-3
Dominant poles	$Q = 9$ $f_0 = 4$ MHz	$Q = 9.0000$ $f_0 = 3.9999$ MHz	$Q = 8.9999$ $f_0 = 4.0000$ MHz
Parasitic poles	None	$Q = 0.5982$ $f_0 = 7.2725$ MHz	$Q = 0.6285$ $f_0 = 7.2234$ MHz $Q = 0.5000$ $f_0 = 63.3326$ MHz
Initial function value	5.0616	5.243 e-1	3.8253 e-6
Minimum function value	2.26008 e-12	1.6921 e-13	2.0067 e-7
Function evaluation	451	451	551

Table 3: Poles specification before and after optimization; example 3:  $f_0 = 200$  KHz,  $Q = 5$ ,  $g_{m1} = g_{m2}$

Poles	Before optimization		After optimization	
	Q	$f_0$ (kHz)	Q	$f_0$ (kHz)
Ideal OTA Dominant	5	204.0366	5.0000	200.0000
One-pole model Dominant*	7.3867	204.3781	4.9999	199.9999
First parasitic pair*	0.5002	6289.4721	0.5002	6283.1520
Two-pole model Dominant**	7.7578	204.3983	5.0000	199.9999
First parasitic pair**	0.5003	6288.6236	0.5003	6280.8895
Second parasitic pair**	0.5000	63002.2897	0.5000	63003.0017

before and after optimization for ideal and non-ideal OTA models. The initial points for all design in this example represent the parameter values (Bowron and Dahir, 1989) which give  $f_0 = 204$  kHz before optimization.

### CONCLUSION

A computer aided design procedure was adapted for the design of 2nd order OTA-C filters taking into

account, the frequency dependent on  $g_m$  model of the OTAs used. The design requirements are met accurately when this non-ideal factor is included. This is achieved with a design procedure based on optimization technique to reduce the effects of the parasitic poles to minimum. The dominate poles that were shifted from there desired locations du to the presence of the parasitic poles are forced to return back to the required position in the complex s-plan therefore, filter specification can be met exactly with the new predistorted circuit parameters.

### REFERENCES

- Al-Taweel, F.M., 2004. Controlled filter with Op-Amp and OTA-C. Proceedings of the 1st Jordan International Conference on Computer Science and Engineering, (JICSEE'04), Al-Balqa University, Jordan -.
- Bowron, P. and H.M. Dahir, 1989. Modelling of nonideal active devices in continuous-time OTA-C filters. Proceedings of the European Conference on Circuit Theory and Design, September 5-8, 1989, Brighton, UK., pp: 128-131.
- Kim, T.G. and R.L. Geiger, 1988. Monolithic programmable RF filter. Electron. Lett., 24: 1569-1571.
- Linares-Barranco, B., A. Rodriguez-Vazquez, E. Sanchez-Sinencio and J.L. Huertas, 1989. 10 MHz CMOS OTA-C voltage-controlled quadrature oscillator. Electron. Lett., 25: 765-767.
- Press, W.H., 1992. Numerical Recipes in FORTRAN: The Art of Scientific Computing. 2nd Edn., Cambridge University Press, Cambridge, ISBN: 9780521430647, Pages: 963.
- Rodriguez-Vazquez, A., B. Linares-Barranco, J.L. Huertas and E. Sanchez-Sinencio, 1990. On the design of voltage-controlled sinusoidal oscillators using OTAs. IEEE Trans. Circuits Syst., 37: 198-211.