

Design, Construction and Application of Effective Electromagnetic Field on Kidney Tissue

¹Nazanin Allahverdizadeh, ²Behzad Yasrebi, ³Alireza Andalib and ⁴Fatemeh Afshari

¹Department of Mechatronics,

²Department of Biomedical Engineering,

³Department of Electrical Engineering, Faculty of Electronics,

⁴Department of Histopathology and Anatomy,

Islamic Azad University, Tabriz Branch, Tabriz, Iran

Abstract: In late years, many researchers have focused on the effects of Electromagnetic Fields (EMFs) on biological tissues. Although, the effects of EMF on live tissues were shown in many studies but even now there is many questions that are not replied. The aim of the present study, is to design and construct an EMF exposure system which can generate 10-100 Hz, 0.1-2 mT EMFs and then study the effects of 50 Hz, 0.1 mT EMF that was generated by this exposure system on kidney tissue of rats. The exposure system consisted of 4 square coils (Merritt 4 coils), the coils are 30 cm in width. About 2 outer coils were of 850 turns and 2 inner coils were of 360 turns of copper wire with 0.5 mm in diameter. The distance between 2 inner coils was 7.668 cm and the distance between inner coils and outer coils was 11.322 cm. The needed current was applied by a signal generator. In order to amplify the signal generator, a push-pull amplifier was designed and constructed. The field at the center of the coils was probed by a magnetic flux meter. To check the accuracy of the exposure system in generating effective EMFs, the effects of 50 Hz, 0.1 mT EMF on kidney tissue of rats were studied. For this purpose, 12 rats divided into 2 control and exposed groups randomly. Exposed rats (6 rats) were exposed to 0.1 mT, 50 Hz EMF, 6 h a day for 30 days. Control rats (6 rats) were housed in a separate room without exposure to EMF. After all applications, kidney tissue of rats was investigated under light microscope. The designed exposure system could generate variable magnetic flux at the center of coil system which could change from 0.1-2 mT in flux density and 10-100 Hz in frequency. Moreover, the microscopic studies on kidney tissues demonstrated that 0.1 mT, 50 Hz EMF affected kidney tissues and compared with control rats, Bowman's capsule of exposed rats was altered. These results demonstrated that designed and constructed EMF exposure system could generate EMFs with different flux densities and frequencies. Also, the generated EMF by this exposure system could affect kidney tissue.

Key words: Electromagnetic field, flux density, frequency, kidney tissue, rat

INTRODUCTION

Electromagnetic Fields (EMFs) exist anywhere in the environment where human being lives. Electricity got into the civilized countries from the mid 20th century and was known as one of the important components of human life (Lacy-Hulbert *et al.*, 1998). Increasing usage of electric appliances has caused many people to be exposed to human made EMFs (Becker and Merino, 1982). These factors have attracted researchers to investigate the effects of electromagnetic fields on living creatures.

In recent years, many studies have focused on the effects of electromagnetic fields on human and animals.

For example, it is known that exposure to EMF influences some biological interactions: Leukocyte-endothelial interaction (Ushiyama and Ohkubo, 2004).

In 2003, a study was done about the effects of 0.8 mT, 50 Hz EMF on Oxidative DNA (Isler and Erdem, 2003). Juishen in 2004 studied the effects of EMF with intensity of 0.1 mT and frequency of 50 Hz on cellular activity of the osteoblast and concluded that the influence of EMF on bone tissue affected the number of cells (Hong-Shong *et al.*, 2004).

The main purpose of the researchers is to investigate the link between electromagnetic fields and biological tissues alteration. Effects of magnetic fields on the electrical properties and enzymes function of rat liver

was studied in 2008 (Sallam and Awad, 2008). Also, 50 Hz magnetic field affected the function of liver in a study by Ibrahim *et al.* (2008).

Some epidemiological studies have been carried out to appraise the effects of electromagnetic fields on pulp tissue of rats. They concluded that osteoporosis affected the odontoblasts and fibroblasts in rat dental pulp, ELF-MF exposure did not resolve the histopathological effects due to osteoporosis but enhance this pathological effect (Kaya *et al.*, 2011).

Considering the importance of the effects of the EMFs on biological tissues and the demand to study the influence of EMFs, in this study EMF exposure system with intensities of 0.1-2 mT and variable frequencies of 10-100 Hz was designed and built. Then the effects of 0.1 mT, 50 Hz EMF was investigated on the kidney tissue of male rats.

Something that distinguished the designed exposure system from others is its ability in producing distinctive, controllable and variable intensities and frequencies, as this feature makes it possible to perform numerous experiments on different biological tissues.

MATERIALS AND METHODS

Mechanical part of the exposure system: The coil system which was chosen to generate electromagnetic field was designed according to Merritt coil system model (Merritt *et al.*, 1983). The designed coil system consisted of 4 wooden frames (as coils) that copper wires were turned around them. All the frames were of the same size: $30 \times 30 \text{ cm}^2$ but different number of turns. The coils were placed horizontally as facing one another. According to Merritt 4 coil system, the ratio of ampere-turn (wire turn) in the inner coil pair to that in the outer coil pair is 2.3612. So in current system, 2 outer coils had 850 turns of lacquer copper wire of 0.5 mm in diameter whereas 2 inner coils had 360 turns of same wire. The important aspect of this system is that the wire in all coils is turned in same direction and connected to each other in parallel. Dimensions of the coils in the cartesian coordinate system are shown in Fig. 1. The dimensions are expressed in terms of variable d and z_i , $i = 1-4$. For the Merritt coil system of 4 square coils the ratio of the distance from center to the inner pair of coils a and the side length of the coils d is $a/d = 0.128106$ and the ratio of the distance b , from the center to the outer pair of coils and d is $b/d = 0.505429$.

In Fig. 1, z_1 and z_4 demonstrated the location of outer coils whereas z_2 , z_3 are the location of inner coils. The distance between z_2 and z_3 and $x = 0$ according to Fig. 1, was $a = 3.8 \text{ cm}$ where the length of distance between z_1 and z_4 and $x = 0$ was $b = 15.16 \text{ cm}$.

The entire coil system was placed inside a protective talc rectangular cube box. According to Fig. 1, a talc plate was placed on the z_3 (approximately center of the coil system) that when animals were placed on that plate, the maximum electromagnetic field would reach them (Fig. 2).

Electrical part of the coil system: The inputs and outputs of each floor of the coil system were connected in parallel. According to Fig. 3, for feeding the coil system and produce the required flow into the coil system, a function generator (GwINSTEK GFG-8020H, Taiwan) was used. Since, the function generator was unable to generate demanded current flow and in order to amplify the function generator, a push-pull amplifier was designed and constructed. It was driven by the 220-80 V and 3 ampere transformer. The output of the function

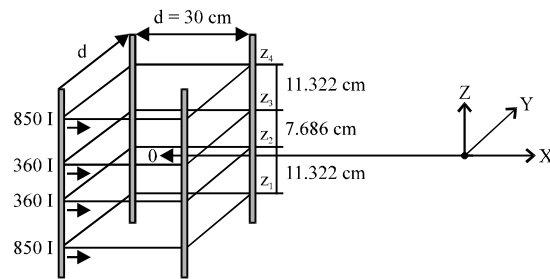

Fig. 1: Configuration of the designed coil system



Fig. 2: Image of the coil and protective talc box

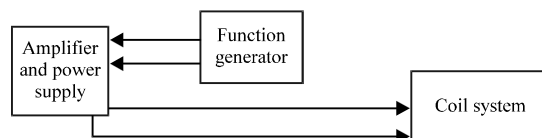

Fig. 3: Electrical connections

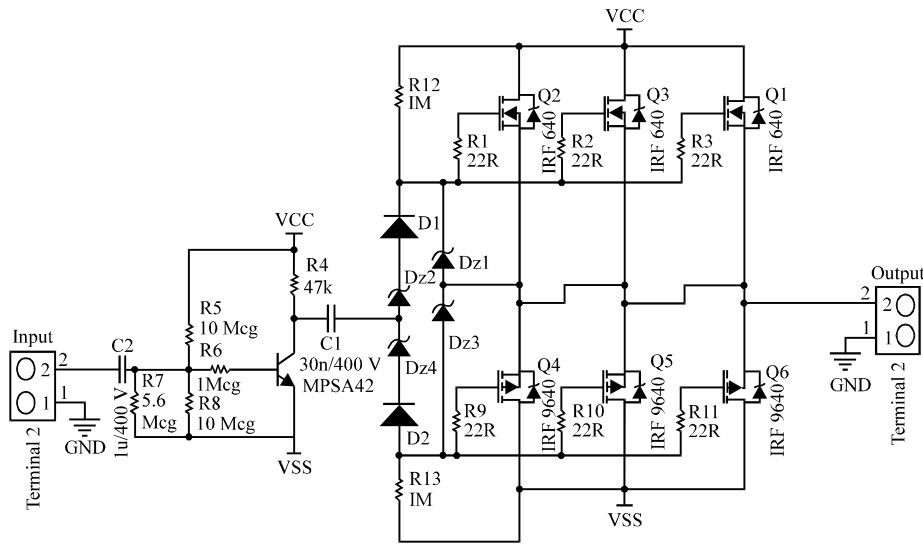

Fig 4: Circuit of the push-pull amplifier

generator was connected to the amplifier input and the output of it was connected with coil system. To prevent increases in temperature inside the amplifier box, 3 fans (Enermax Magma-UCMA 12) were utilized as necessary.

The design of the amplifier circuit was done in Protel DXP application (Fig. 4). Since, the coil system needed high current flow (about 3 amperes) and the function generator was unable to generate that much flow, so the amplifier circuit was designed in order to tolerate that high flow. For this reason, common emitter transistor, mosfet transistors were used in the circuit.

EMF of the exposure system: A function generator is able to change sinusoidal frequencies. In consideration of the designed system, a function generator was needed to generate signals in 10-100 Hz frequencies. The generated signals were amplified by the designed push-pull amplifier. The task of the push-pull was to distribute greatest effect on the current flow. On the other hand, the common emitter transistor was designed to boost the voltage. So in order to increase and decrease the intensity of the EMF, the amplitude of the produced signals by the function generator was changed to cause voltage change. In fact by adjusting the function generator onto the desired frequency (10-100 Hz) and by changing the range of the amplitude of the function generator, variable intensities and frequencies of EMF were produced. The field at the center of the coils was probed by a tesla meter (Leybold, Germany) and the results were recorded (Fig. 5).

Animals: In order to case study, the effectiveness of the exposure system on kidney tissue of the male rats, 0.1 mT, 50 Hz EMF was generated. The amplitude of the function

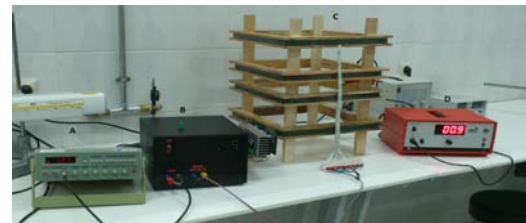

Fig. 5: Exposure system: A) Function generator; B) Amplifier; C) Coil system D) Tesla meter

generator was adjusted onto 20 V and the frequency of 50 Hz to produce the EMF. The current flow in the wires of the energized exposure coils was 2 A for 0.1 mT which resulted 50 Hz EMF.

Total 12 male Wistar rats were used in this experiment; they were 2 months old with initial weight of 200 g at the beginning of the study. All rats were allowed free access to water and standard food diet during the experimental period. The rats were divided into 2 groups (6 rats per group) randomly:

- Group 1 = Control group (n = 6)
- Group 2 = Exposed group (n = 6)

Exposed group animals were exposed to 0.1 mT, 50 Hz EMF exposure during 1 month, 6 h a day. Control group were treated like exposed group except applying EMF exposure to rats in this group and the completed their life cycle in the cage during the study period. The rats were free to move inside the coil system.

Biomedical analysis: Immediately after the last exposure to EMF, kidney tissues of the experimental animals were removed. Samples were fixed in 10% formalin for 48 h and

processed in tissue processing device. The samples were embedded in melt paraffin and the slices with diameter of 5 μm sections were produced by rotator microtome (Therma Shandon, England). All the sections stained with H&E technique for microscopic examination (Leica, USA).

RESULTS

The results of the electromagnetic field exposure system:

In order to get the current flow of the coil, a multi meter (Best, China) was used. For this purpose, the output of the multi meter and amplifier were connected in series. The multi meter was set to 20 A, ac. Then by changing the frequency range of the function generator from 10-100 Hz, the current flow in each frequency was recorded.

Also to get the voltage of the coil, the output of the multi meter and amplifier was connected in parallel. The grade of the multi meter was set to 200 V, ac. Then the voltage in each frequency was measured by changing the amplitude of the signal generator in 10-100 Hz frequencies.

Finally, the distribution of the magnetic flux densities were measured along z-axis for sinusoidal current by a calibrated tesla meter (Leybold, Germany).

Table 1 shows the results obtained for magnetic flux density (B), current flow and voltage in frequencies from 10-100 Hz. These results confirm that the system can generate different magnetic flux densities with different frequencies.

Also, Fig. 6 shows measured results for magnetic flux density (B) by tesla meter together with analytical results that was calculated using:

$$B = 1.795 \cdot 10^{-6} \cdot NI/d$$

Where:

N = The number of turns in the outer coil

I = The current (Ampers)

d = The side length of the square coils (m)

The results of effectiveness on kidney tissue: The microscopic studies on kidney tissue demonstrated that 0.1 mT, 50 Hz EMF caused Bowman capsule alteration in axposed group (Fig. 7 and 8).

Table 1: The results obtained for magnetic flux density (B), current flow and voltage in different frequencies from 10-100 Hz

Frequency (Hz)	Current flow		Magnetic flux density (mili tesla)
	(Ampers)	Voltage (V)	
10	4/1	25	1/0
20	7/1	35	6/0
30	2/2	49	2/1
40	4/2	60	7/1
50	2	67	2
60	3/2	72	8/1
70	1/2	74	7/1
80	9/1	74	5/1
90	7/1	73	3/1
100	5/1	72	1

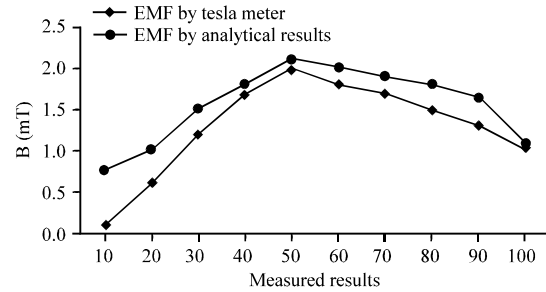

Fig. 6: Measured results for magnetic flux density (B) by tesla meter together with analytical results

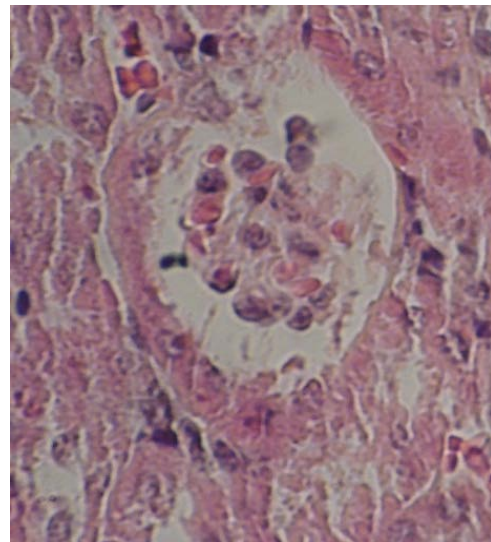

Fig. 7: Microscopic image of Bowman capsule in control rats (H&E, 400x)

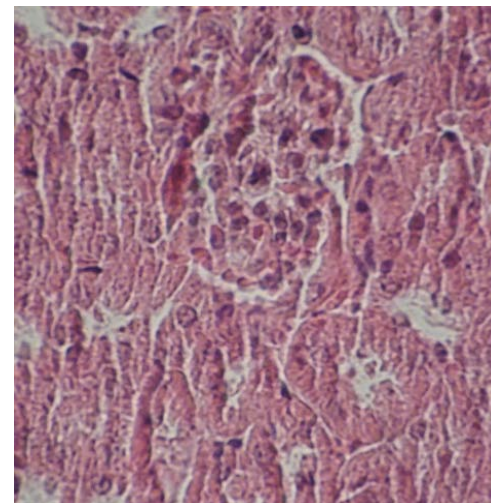

Fig. 8: Microscopic image of Bowman capsule in exposed rats (H&E, 400x)

DISCUSSION

The designed and constructed EMF exposure system is very useful to generate volumes of uniform electromagnetic fields. In this study to design the EMF exposure system, various systems that were offered by scientists and researchers in the world were studied and reviewed. From among these systems, Merritt coil system was chosen to be developed and constructed. The reason was that Merritt coil system with 4 coils gives better results and is easy to construct compared with other coil systems. Merritt *et al.* (1983) introduced Merritt coil system as the best system in generating uniform electromagnetic fields. On the other hand Magdaleno-Adame *et al.* (2010), compared different EMF exposure systems and have concluded that Merritt coil system have better results than other coil systems.

To amplify the function generator in order to make it generate high current, a push-pull amplifier was designed. The main objective of using this amplifier is to get a weak signal from function generator and make it stronger. The reason for using an enhanced signal is to create a provocation in a means that there is no possibility of stimulation in it because of the low range of input signal. The only difference between the input and the output of the amplifier is the strength of the signals.

Current study showed 6 h of 50 Hz, 0.1 mT EMF exposure, made some changes in kidney tissue. Also, compared with control rats, Bowmans capsule of exposed rats was altered. Another effects of EMF on kidney tissue showed that EMF can change the distribution of TJ and AJ structural proteins (Somosy *et al.*, 2004). A study demonstrated that EMF exposure could immediately destroy the metabolism of the free radicals and GSH content in kidney (Koyu *et al.*, 2009). Zecca *et al.* (1998) demonstrated the effects of EMF on different parts of the kidney tissue.

CONCLUSION

As a fact when a large volume of electromagnetic field is needed, it is better to use coil systems like solenoids, Helmholtz, Merritt or other coil systems. Merritt square coil system was easy to construct than other coils. The goal of this study was to design and construct an EMF exposure system which could generate different flux intensities in various frequencies. So the designed EMF exposure system was able to generate 0.1-2 mT EMFs in frequencies of 10-100 Hz. On the other hand, the effectiveness of the exposure system was tested on kidney tissue of rats and concluded that it could cause changes in inflammatory cells of Rental cortex and Bowman capsule of kidney tissue in exposed rats.

REFERENCES

- Becker, R.O. and A. Merino, 1982. Electromagnetism and Life. Suny Press, Albany State University of Newyork.
- Hong-Shong, W.C., L.T. Chen, J.S. Sun and F.H. Lin, 2004. Effect of pulse-burst electromagnetic field stimulation on osteoblast cell activities. *Bioelectromagnetics*, 25: 457-465.
- Ibrahim, M., M. El-Ashry and E. Ali, 2008. The influence of 50 Hz magnetic field on liver function. *Romanian J. Biophys.*, 18: 113-122.
- Isler, S. and G. Erdem, 2003. The effect of electromagnetic fields on oxidative DNA damage. *J. Cell Mol. Biol.*, 2: 35-38.
- Kaya, S., M. Celik, M. Akdag and O. Adiguzel, 2011. Effects of Extremely low frequency magnetic field on pulp tissue of rats. *J. Anim. Vet. Adv.*, 10: 295-300.
- Koyu, A., F. Ozgur, H. Yilmaz, F. Uz, G. Cesur and N. Ozcelik, 2009. The protective effect of caffeic acid phenethyl ester (CAPE) on oxidative stress in rat liver exposed to the 900 MHz electromagnetic field. *Toxicol. Ind. Health*, 25: 249-340.
- Lacy-Hulbert, A., J.C. Metcalfe and R. Hesketh, 1998. Biological responses to electromagnetic fields. *FASEB J.*, 12: 395-420.
- Magdaleno-Adame, S., J.C. Olivares-Galvan, E. Campero-Littlewood, R. Escarela-Perez and E. Blanco-Brisset, 2010. Coil systems to generate uniform magnetic field volumes. *Proceedings of the COMSOL Conference*, April 5, 2010, Boston.
- Merritt, R., C. Percell and G. Stronik, 1983. Uniform magnetic field produced by three, four and five square coils. *Rev. Sci. Instrum.*, 54: 879-882.
- Sallam, M.S. and A.M. Awad, 2008. Effects of static magnetic field on the electrical properties and enzymes function of rat liver. *Romanian J. Biophys.*, 18: 337-347.
- Somosy, Z., Forgacs, G. Bognar, K. Horvath and G. Horvath, 2004. Alteration of light and adherence junctional on 50 Hz magnetic field exposure in Modin Darby Canine Kidney cells (MDCK). *Sci. World J.*, 2: 75-82.
- Ushiyama, A. and C. Ohkubo, 2004. Acute effects of low frequency electromagnetic fields on Leukocyte-endothelial interactions *in vivo*. *In vivo*, 18: 125-132.
- Zecca, L., C. Mantegazza, V. Margonato, P. Cerretelli and M. Caniatti *et al.*, 1998. Biological effects of prolonged exposure to ELF electromagnetic fields in rats: III. 50 Hz electromagnetic fields. *Bioelectromagnetic*, 19: 57-66.