

## A New Adaptive Control of Switched Mode DC-DC Converter Based on DCD-RLS Algorithm IIR Filter

<sup>1</sup>M. Shankar, <sup>2</sup>S.D. Pravinkumar, <sup>2</sup>R. Venkatesh and <sup>2</sup>G. Gowrishankar

<sup>1</sup>Department of Electrical and Electronics Engineering,

<sup>2</sup>Department of M.E Power Electronics and Drives, Sasurie College of Engineering,  
Vijayamangalam, India

---

**Abstract:** Many industrial supplies depends on switched mode power supplies, they need well regulated supply. For this a new online system identification is used. The proposed method can be applied to many alternative applications where efficient and accurate parameter estimation is required. In the existing method, a three mode PID controller is used which offer several disadvantage which need a continuous tuning and constant gain parameter. The proposed method uses the fuzzy logic controller for the voltage compensation where the design is based on the knowledge base and rule base and the above disadvantage can be eliminated. The novel technique is computationally efficient, based on a dichotomous coordinate descent algorithm and uses an infinite impulse response adaptive filter as the plant model. Simulation analysis and validation based on experimental data obtained from a DC-DC buck converter is validated using MATLAB/SIMULINK.

**Key words:** Adaptive filter, Dichotomous Coordinate Descent (DCD), switch mode DC-DC power converter, Infinite Impulse Response (IIR) adaptive filter, Recursive Least Squares (RLS), system identification

---

### INTRODUCTION

Many industrial and consumer devices are depends on Switched-Mode Power Converters (SMPCs) to provide a reliable, regulated, DC power supply. A poorly regulating power supply can reduce the operating range of the device. To provide accurate voltage regulation of the SMPC, optimal control of the power converter output is required.

The SMPC output affected from such as component tolerances, unpredictable load changes, variation in ambient conditions and ageing effects affect the performance of the controller. To compensate for these time varying problems, here researchers now applying a novel adaptive control techniques in SMPC applications. Clearly for a high performance controller with good dynamic performance, accurate parameter estimation of the system is essential. In SMPC applications, it is also necessary to require the system parameters rapidly. The time constants in Pulse Width Modulation (PWM) switched power converters are often very short and it is not uncommon for abrupt load changes to be observed. Any system identification scheme must be able to respond appropriately to these characteristics. However, achieving improved accuracy and/or speed also implies the need for a faster, more powerful microprocessor

platform. This is not always viable in SMPC applications especially small, high volume systems where it is essential to keep system costs low and competitive. Therefore, there is a need for computationally light system identification schemes which enable these advanced techniques to be performed on lower cost hardware.

### SYSTEM IDENTIFICATION TECHNIQUES

When identifying the model of the unknown system, there are two system identification approaches can be used. They are parametric estimation and non parametric estimation techniques. Recent research demonstrates several productive parametric and non-parametric system identification techniques for power electronic converter applications. Nonparametric methods use spectral analysis and correlation analysis method to estimate the frequency response of the system. The behavior of the system is then estimated from the frequency response without using any parametric modeling (Miao *et al.*, 2005a; Zhenyu and Prodic, 2007; Barkely and Santi, 2009). In SMPC applications, nonparametric methods often consider disturbing the duty cycle with a frequency rich input signal; for example, a Pseudo Random Binary Sequence (PRBS) (Barkely and Santi, 2009). Typically, fourier transform methods are then applied to find the

frequency response of the system. Unfortunately, the identification process can take large amount of time to complete they need to process a long data sequences (Peretz and Ben-Yaakov, 2007). In addition during the identification process, the system operates in open loop without regulation (Pitel and Krein, 2008).

In parametric estimation techniques, a model structure is proposed (Barkely and Santi, 2009) and the parameters of the model are identified using information extracted from the system (Miao *et al.*, 2005b). The selected candidate model is always application dependent and its complexity is often subject to the approximations which can be made. For example, a DC-DC buck converter can be represented as a second-order Infinite Impulse Response (IIR) filter (Kong *et al.*, 2009). This provides an average model of the converter and will characterize the basic operation of the system. It will not, however show the PWM switching frequency component in the output voltage. Provided the switching behavior is not of immediate concern, the second order candidate model will suffice. Once the plant model has been chosen, several approaches can be used to identify the system parameters; for instance, least mean squares, Recursive Least Squares (RLS), maximum likelihood and subspace methods. Recursive identification methods are a very familiar approach in online applications. However, these methods and in particular RLS, are not fully exploited in low-cost, low-power SMPCs due to the computational complexity of the identification algorithm which may require a high specification microprocessor to successfully implement. Clearly, this is not desirable from an industry point of view where minimal cost and low complexity are key design drivers.

Unfortunately in many of the methods presented, significant signal processing is required to implement

these schemes and this ultimately has a cost penalty for the target application. Furthermore, the computational complexity impacts upon time of execution in the microprocessor and this in turn makes it difficult to adopt in continuous parameter estimation adaptive control applications (Zhenyu and Prodic, 2007). For this reason in this study, an RLS algorithm is implemented using a fast, computationally light, hardware efficient, adaptive algorithm, known as Dichotomous Coordinate Descent (DCD) (Miao *et al.*, 2005a). This algorithm has previously been developed for use in the field of telecommunications. Here, researchers adapt the algorithm and apply it for the 1st time in the system identification of power electronic circuit.

### SYSTEM IDENTIFICATION OF DC-DC CONVERTER USING ADAPTIVE IIR/DCD-RLS ALGORITHM

Figuer 1 illustrates a block diagram of the proposed system identification scheme. Here, a closed-loop DC-DC buck converter is controlled via a fuzzy logic controller. In addition, a real time system identification algorithm is inserted alongside the controller, continually updating the parameters of the buck converter system on a sample by sample basis. The identification system can be enabled and disabled on demand during operation. For example, it may be applied at start-up, at regular set intervals or enabled on detection of a system change such as a variation in the system load. Monitoring the voltage loop error is one simple way to detect a system change and enable the system identification process. When enabled, a small high-order excitation signal is injected into the control loop. This is required to improve the convergence time of the adaptive filter; this is the time to obtain optimal filter tap weights for accurate parameter estimation. For all

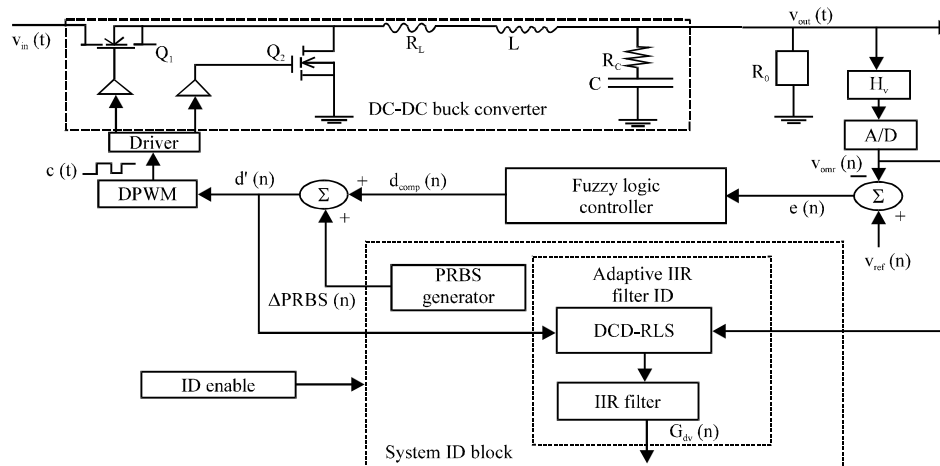

Fig. 1: Closed loop buck converter control using adaptive technique

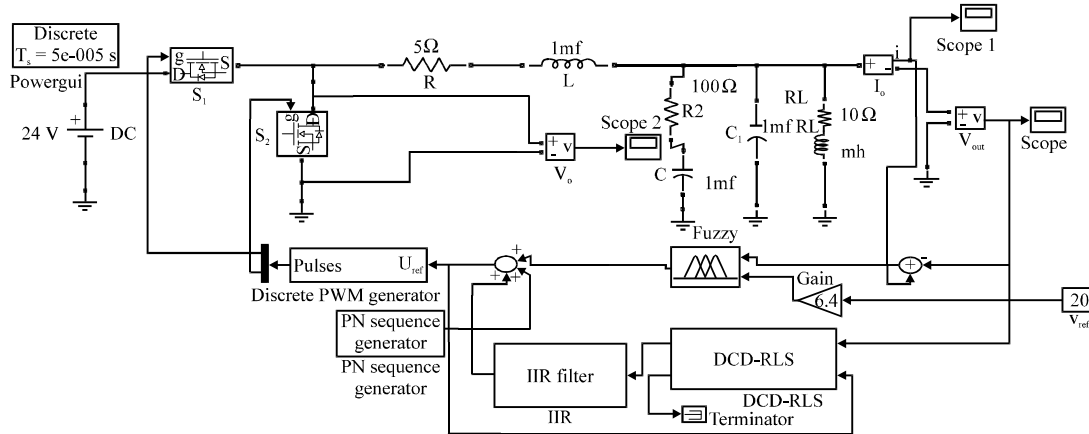

Fig. 2: Simulation for buck converter

online identification methods, some form of system perturbation is essential for the estimation process (Peretz and Ben-Yaakov, 2007).

In this scheme, the PRBS is selected. As shown in Fig. 1, the PRBS signal is added to the fuzzy controller output signal,  $d_{comp}(n)$ . This creates a control signal  $d(n)$  with a superimposed persistent excitation component. Once applied to the PWM, a small disturbance in the output duty cycle  $c(t)$  is generated. In this way, the duty cycle command signal at steady state will vary between  $d_{comp}(n) \pm \Delta_{PRBS}(n)$ . Practically, in order to focus the identification on the frequency range of interest and remove unwanted high-frequency measurement noise, the inputs to the DCD-RLS algorithm require filtering prior to identification. This can be accomplished by designing a digital low-pass or band pass, filter. In addition, offset in the input signals must be removed as the RLS algorithm assumes zero mean values in the input signals. In DC-DC SMPC applications, it is easier to remove offsets on a cycle-by-cycle basis from the input signals where steady-state average values of the regulated output voltage and the average duty-cycle ratio are known. At each time instance, the average value of the input signal is directly subtracted from the excited signal. A low pass filter can also be used to remove the offset from the input signals; however this will add more computation to the overall system which is not essential in the online system identification process. Once the samples have been processed, they are passed to the identification algorithm (DCD-RLS block in Fig. 1) to estimate the system parameters and update the discrete IIR filter model of the SMPC.

An adaptive filter can have different structures depending upon its application which may be noise cancellation, signal prediction or system identification (Pitel and Krein, 2008; Peretz and Ben-Yaakov, 2011). In this study, researchers employ an adaptive IIR filter for

system identification. An adaptive filter may be defined as a self-designing filter (Hu *et al.*, 2005) where the filter coefficients are continuously varying until the objective function is achieved (Peretz and Ben-Yaakov, 2011). As shown in Fig. 2, the adaptive filter consists of two key components, the digital filter and the adaptive filter algorithm which are used to vary the tap-weight coefficients in real time.

### DCD AND RLS ALGORITHM

Least squares estimation techniques are fundamental in adaptive signal processing applications. In real-time applications (Peretz and Ben-Yaakov, 2011), the solution is normally based on matrix inversion which is computationally heavy and presents implementation difficulties. The DCD algorithm appears to be a particularly effective method (Hu *et al.*, 2005; Miao *et al.*, 2005b; Zhenyu and Prodic, 2007). Attractively, the computation is based on an efficient, fixed-point, iterative approach with no explicit division operations (Kong *et al.*, 2009). This makes it very appropriate for real-time hardware implementation. The computational requirement of the DCD algorithm depends mainly upon the number of iterations  $N_u$  used to update the parameters. The iteration number also determines the speed and accuracy of the process (Miao *et al.*, 2005a).

### MODEL EXAMPLE AND SIMULATION RESULTS

Usually, system identification performance is measured using particular metrics such as convergence time, parameter accuracy and prediction error (Miao *et al.*, 2005b). These metrics determine how closely the identified model matches the actual system transfer function (Algreer *et al.*, 2009) and they are used to evaluate the proposed method in this study. To test the

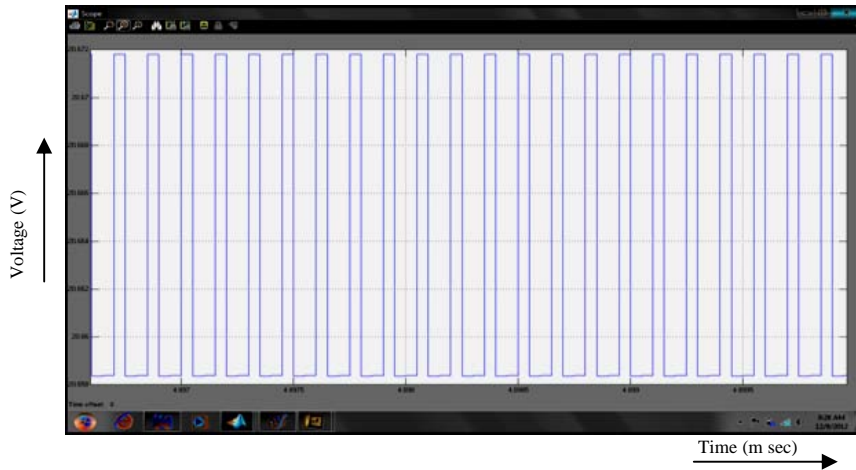

Fig. 3: Output of the buck converter

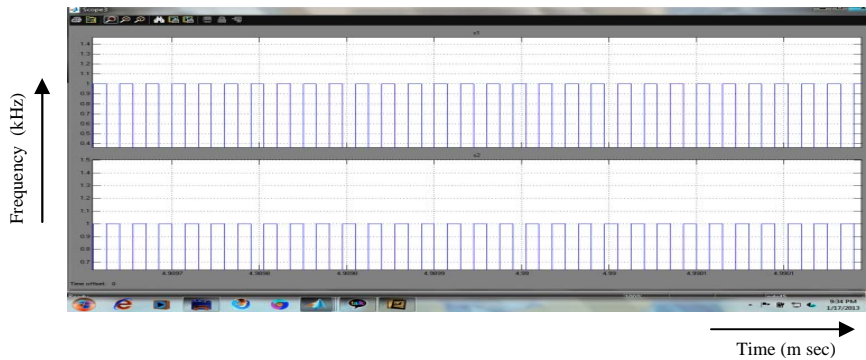

Fig. 4: PWM for the switches

concept of the proposed DCD-RLS identification scheme (Fig. 1), a voltage controlled DC-DC buck SMPC circuit has been simulated using MATLAB/Simulink. The circuit parameters of the buck converter are  $R_{lo} = 100 \Omega$ ,  $R_L = 10 \text{ m}\Omega$ ,  $R_c = 5 \Omega$ ,  $L_c = 1 \text{ mH}$ ,  $C = 1 \mu\text{F}$ ,  $V_o = 20 \text{ V}$ ,  $V_{in} = 24 \text{ V}$ . The buck converter is switched at 20 kHz and the output voltage is also sampled at the same switching frequency rate. The simulation diagram for the buck converter is shown in Fig. 3. The model contains DC voltage source, power switches like MOSFET, pseudo random binary sequence generator and PWM generator to provide pulse signal to the MOSFET. Based on the mentioned before values, the simulation is verified.

From the mention earlier, simulation the buck converter are modeled based on the parameter given and the experiment results is validated. Here, fuzzy logic controller is used for voltage compensation and an adaptive algorithm DCD-RLS algorithm is used as an control law. The overall simulation result for the buck converter is shown in Fig. 4. In this simulation the output is maintained constant while varying the load. The

reference voltage is given to the fuzzy controller which compares the set point and the output voltage across the load. Depending on output voltage the PWM is generated and applied to the PWM controller which is given to the PWM controller block. For the design of the buck converter the input voltage applied is 24 V and the output voltage is 20 V measured across the load.

For the PWM signal the switch  $s_1$  act as an switching purpose and the switch  $S_2$  act as an blocking purpose which is connected parallel to the  $S_1$  to protect the  $s_1$  under the reverse voltage.

### CONCLUSION

The disturbances in power electronics, such as component tolerance and sudden load change in the output of the DC-DC converter. Most of the case, there may be poor regulation of the output. The output of the converter can be maintained constant whatever the load disturbance can be varied. So by using the adaptive control technique, the output can be maintained constant. In the parameter estimation least square method like

DCD-RLS algorithm which provide the faster convergence and accurate parametric identification. The process is based on error equation IIR filter scheme which is well suited for parameter estimation for SMPC. Therefore, proposed method is able to work in closed loop and able to minimize the prediction error.

#### REFERENCES

- Algreer, M., M. Armstrong and D. Giaouris, 2009. System identification of PWM dC-dC converters during abrupt load changes. Proceedings of the 35th Annual Conference of IEEE Industrial Electronics, November 3-5, 2009, Porto, pp: 1788-1793.
- Barkely, A. and E. Santi, 2009. Improved online identification of a DC-DC converter and its control loop gain using cross-correlation methods. IEEE Trans. Power Electron., 24: 2021-2031.
- Hu, C.C., H.Y. Lin and J.H. Wen, 2005. An adaptive fuzzy-logic variable forgetting factor RLS algorithm. Proceedings of the 62nd IEEE Vehicular Technology Conference, September 25-28, 2005, Dallas, Texas, USA, pp: 1412-1416.
- Kong, N., A. Davoudi, M. Hagen, E. Oettinger, X. Ming, H. Dong Sam and F.C. Lee, 2009. Automated system identification of digitally-controlled multi-phase DC-DC converters. Proceedings of the 24th Annual IEEE Applied Power Electronics Conference and Exposition, February 15-19, 2009, Washington, DC, pp: 259-263.
- Miao, B., R. Zane and D. Maksimovic, 2005b. Automated digital controller design for switching converters. Proceedings of the 36th IEEE Power Electronics Specialists Conference, June 16-16, 2005, Recife, pp: 2729-2735.
- Miao, B., R. Zane and D. Maksimovic, 2005a. System identification of power converters with digital control through cross-correlation methods. IEEE Trans. Power Electron., 20: 1093-1099.
- Peretz, M.M. and S. Ben-Yaakov, 2007. Time domain identification of PWM converters for digital controllers design. Proceedings of the IEEE Power Electronics Specialists Conference, June 17-21, 2007, Orlando, FL, pp: 809-813.
- Peretz, M.M. and S. Ben-Yaakov, 2011. Time-domain design of digital compensators for PWM DC-DC converters. IEEE Trans. Power Electron., 27: 284-293.
- Pitel, G.E. and P.T. Krein, 2008. Real-time system identification for load monitoring and transient handling of DC-DC supplies. Proceedings of the IEEE Power Electronics Specialists Conference, June 15-19, 2008, Rhodes, pp: 3807-3813.
- Zhenyu, Z. and A. Prodic, 2007. Limit-cycle oscillations based auto-tuning system for digitally controlled DC-DC power supplies. IEEE Trans. Power Electron., 22: 2211-2222.