

## Parameter Tuning for Improved Dynamic Response of Indirect Stator Flux Oriented Induction Motor Drives

<sup>1</sup>M.R. Rashmi, <sup>2</sup>S. Rajapandian and <sup>1</sup>S. Devegowda

<sup>1</sup>Sathyabama University,

<sup>2</sup>Panimalar Engineering College, Chennai, India

**Abstract:** Sensorless vector control of an induction motor drive essentially means vector control without any speed sensors. An incremental shaft mounted speed encoder (usually an optical type) is required for the closed loop or position control in both vector and scalar controlled drives. A speed signal is also required in indirect vector control in the whole speed range and in direct vector control for the low speed range, including the zero speed start-up operation. A speed encoder is undesirable in a drive because it adds cost and reliability problems, besides the need for shaft extension and mounting arrangement. It is possible to estimate the speed signal from machine terminal voltages and current. In order to eliminate the speed sensor, an adaption algorithm for tuning the rotor speed is proposed in this study. Based on model referencing adaptive system scheme, the rotor speed is tuned to obtain an indirect stator flux oriented control. The machine parameters are tuned in such a way to reduce the transient time of the drive. Experimental results obtained for a 1.5 Hp, 3 phase induction machine are presented in this study, showing the effectiveness of the proposed method in terms of dynamic response.

**Key words:** Induction motor drives, vector control, sensorless control, model referencing adaptive system, indirect stator field orientation, rotor speed estimation

### INTRODUCTION

The AC induction motor has been gradually replacing the DC motor in many applications due to reliability, ruggedness and relatively low cost. The control and estimation of AC drives in general are considerably more complex than those of DC drives and this complexity increases substantially if high performances are demanded. However, using power electronic converters and fast digital signal processors, the implementation of advanced controllers is becoming practical (Lee and Blaabjerg, 2006).

For high performance vector controlled induction motor drives, speed information is necessary. This information is generally provided by a sensor, such as a resolver or an encoder. Due to the cost and fragility of mechanical speed sensors and difficulty of installing that kind of sensor in many applications, speed sensorless systems, in which rotor speed measurements are not available, are preferred and find applications in many areas such as mechanical tool drives, robotics manipulators etc. The advantages of speed sensorless induction motor drives are reduced hardware complexity and lower cost, reduced size of the drive machine,

elimination of the sensor cable, better noise immunity, increased reliability and less maintenance requirements. The operation in hostile environment requires a motor without speed sensor.

Several schemes have been proposed for speed sensorless vector controlled induction motor drives, which implies the estimation of mechanical speed from the only measurements of the stator currents and voltages. Among the various approaches, the observer based (Tajima and Guidi, 2002; Cao-Minh and Hori, 2001; Edward and Thomas, 2008; Lee *et al.*, 1997; Boukas and Habetler, 2004; Peng and Fukao, 1993) and the Model Reference Adaptive System (MRAS) based speed estimators are the most promising ones. In addition to estimation of the mechanical speed, the MRAS based scheme provides flux estimate, which can be used in the control of the induction motor drive. MRAS based estimators are preferred because of their simplicity, ease of implementation and stability.

This study describes about overcoming the problem associated with zero speed and low speed estimation and control and also how to attain quick dynamic stability (Holtz, 2002) during the switching of the various magnitudes of loads.

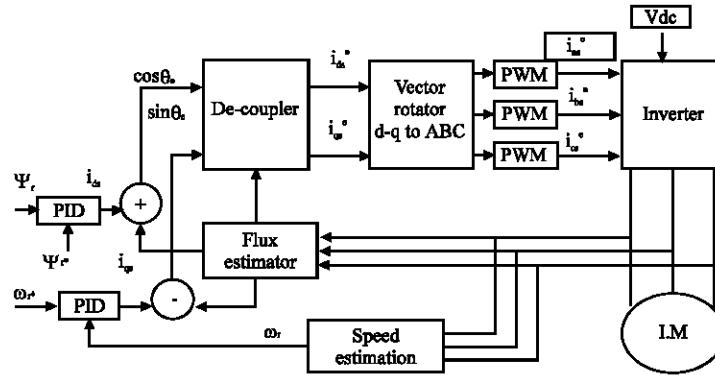

Fig. 1: Block diagram of sensorless control of induction motor

**MODELING OF INDUCTION MOTOR**

The dynamic model considers the instantaneous effects of varying voltage/currents, stator frequency and torque disturbance. The dynamic model of the induction motor is derived by using a two phase motor in direct and quadrature axes. This approach is desirable because of the conceptual simplicity obtained with 2 sets of windings, one on the stator and the other on the rotor. The equivalence between the three phase and 2 phase machine model is derived from simple observation and this approach is suitable for extending it to model an n-phase machine by 2 phase machine. Generally, the machine model are used to estimate the motor shaft speed and in high performance drive with field oriented control to identify the time varying angular position of the flux vector. In addition, the magnitude of flux vector is estimated for field control. The stator model is used to estimate the stator flux linkage vector or the rotor flux linkage vector without requiring a speed signal. It is therefore, a preferred machine model for sensorless speed applications.

**INDUCTION MOTOR SENSORLESS CONTROL**

The schematic diagram of control strategy of induction motor with sensorless control is shown in Fig. 1. The controlled voltage to the stator windings of an induction motor is fed through PWM inverter which in turn driven by vector rotator. The stator flux is estimated by flux estimator. The speed at the motor shaft is estimated by using the motor terminal voltages and the currents. The speed estimation is done by model referencing adaptive system, which is described in Fig. 2. The flux and speed information is fed to the PID controllers, which will generate the output according to the required control strategy. The controller output is given to a De-coupler, which in turn connected to vector rotator, which converts 2 phase quantities to 3 phase. These signals are given to PWM controller.

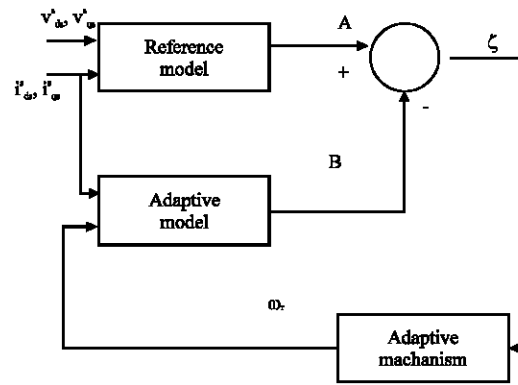

Fig. 2: Basic block diagram of mras speed estimation

**MODEL REFERENCING ADAPTIVE SYSTEM (MRAS) CONTROL**

The speed can be calculated by the MRAS. The basic block diagram of MRAS speed estimation system is shown in Fig. 2. The MRAS makes use of redundancy of 2 machine model of different structures that estimate the same state variables. Both models are referred in the stationary frame. As the name implies, it consists of 2 models namely reference model and the adaptive model. The output of reference model is compared with the output of an adjustable or adaptive model until the errors between the 2 models vanish to zero.

Consider the voltage model's stator side equation,

$$\frac{d}{dt} (\Psi_{dr}^s) = \frac{L_r}{L_m} v_{ds}^2 - \frac{L_r}{L_m} (R_s + \sigma L_s S) i_{ds}^s$$

$$\frac{d}{dt} (\Psi_{qr}^s) = \frac{L_r}{L_m} v_{qs}^2 - \frac{L_r}{L_m} (R_s + \sigma L_s S) i_{qs}^s$$

which are defined as a reference model in Fig. 2. The model receives the machine stator voltage and current signals and calculates the rotor flux vector signals. The current model flux equation,

$$\frac{d\Psi_{dr}^s}{dt} + \frac{R_r}{L_r} (L_m i_{ds}^s + L_r i_{dr}^s) + \omega_r \Psi_{qr}^s = \frac{L_m R_r}{L_r} i_{ds}^s$$

$$\frac{d\Psi_{qr}^s}{dt} + \frac{R_r}{L_r} (L_m i_{qs}^s + L_r i_{qr}^s) + \omega_r \Psi_{dr}^s = \frac{L_m R_r}{L_r} i_{qs}^s$$

are defined as an adaptive model in Fig. 2. This model calculates fluxes from the input stator currents only if the speed signal  $\omega_r$  is known.

With correct speed signal, ideally, the fluxes calculated from the reference model and those calculated from the adaptive model will match. An adaptation algorithm with P-I control can be used to tune the speed  $\omega_r$  so that the error  $\zeta = 0$ .

### MRAS BASED SENSORLESS VECTOR CONTROL-SIMULATION

The sensorless control of induction motor using MRAS is simulated on matlab/simulink platform to study the various aspects of the controller.

The actual system can be modelled with a high degree of accuracy in this package. Figure 3 shows the

root block simulink diagram for simulation. Main subsystems are the 3-2 phase transformation, induction motor model, MRAS and optimal switching logic and inverter.

Three to 2 phase transformation subsystem is used to convert 3 phase stator voltages and currents into 2 phase direct and quadrature axis voltages and currents, respectively.

Optimal design of an induction motor with the below given parameters is selected to reduce the transient time.

**Simulation parameters:** The parameters for 1.5 Hp, 4-pole, 50 Hz induction motor are given below:

- Stator circuit resistance -4.495  $\Omega$
- Rotor circuit resistance -5.365  $\Omega$
- Inductance of stator circuit -0.165 H
- Inductance of rotor circuit -0.162 H
- Mutual inductance -0.149 H

### SIMULATION RESULTS

The results for different cases are given.

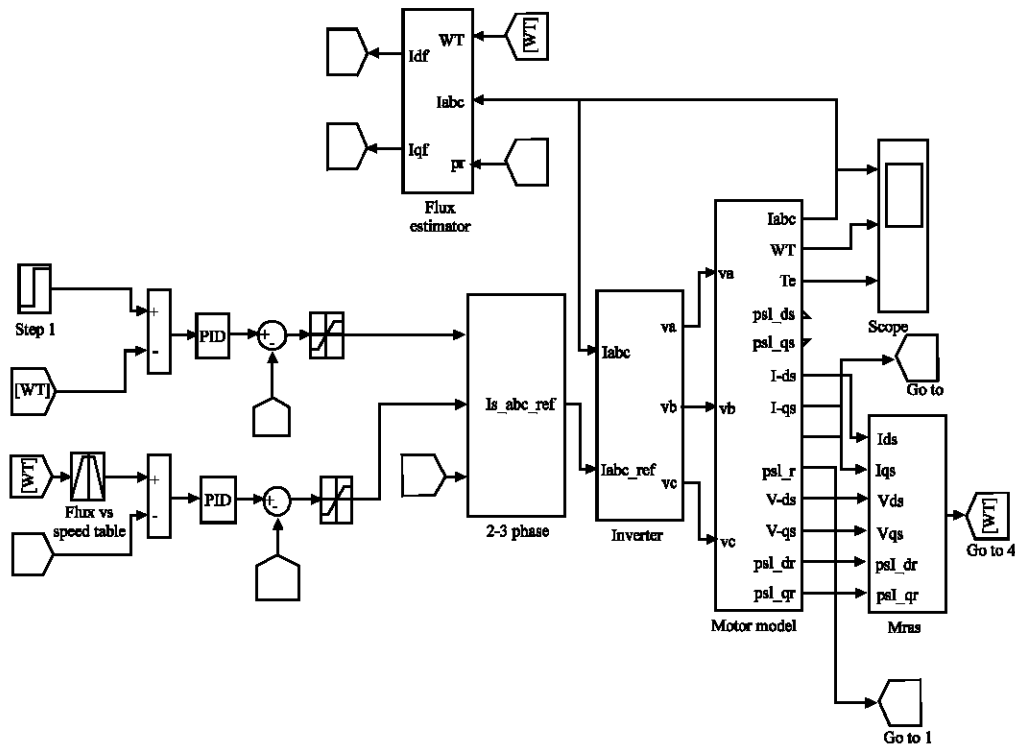

Fig. 3: Simulink root block diagram of sensorless control of induction motor using MRAS

**Case 1:**

- No. load condition
- Reference speed  $-100 \text{ rad sec}^{-1}$

**Comments:** Figure 4 shows that the actual speed of induction motor and the estimated speed using MRAS are same.

Figure 5 shows direct and quadrature axis currents ( $I_{ds}$  and  $I_{qs}$ ). From Fig. 5, it is observed that both the currents are displaced by  $90^\circ$ . Hence, the coupling effect can be eliminated.

Figure 6 shows direct and quadrature axis voltages ( $V_{ds}$  and  $V_{qs}$ ). From Fig. 6, it is observed that both the currents are displaced by  $90^\circ$ . Hence, the coupling effect can be eliminated.

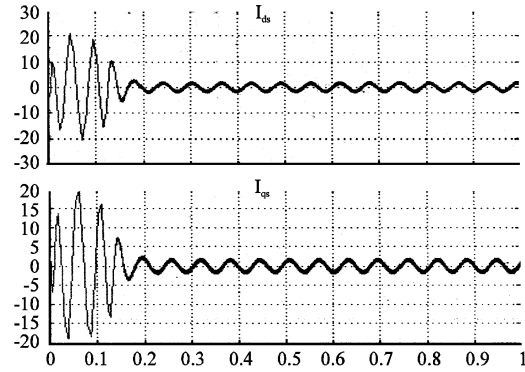

Fig. 5: Direct and quadrature axis currents ( $I_{ds}$  and  $I_{qs}$ )

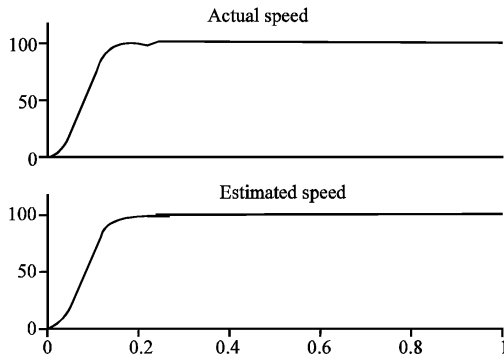

Fig. 4: Actual speed and estimated speed using MRAS in  $\text{rad sec}^{-1}$

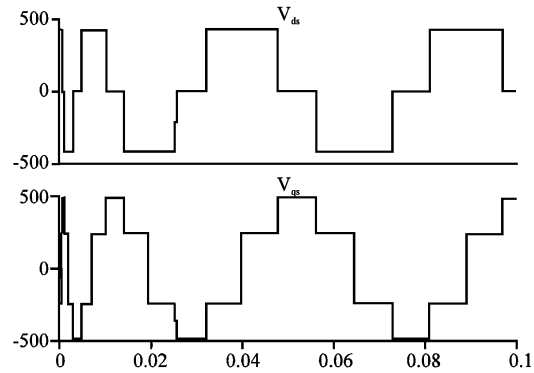

Fig. 6: Direct and quadrature axis voltages ( $V_{ds}$  and  $V_{qs}$ )

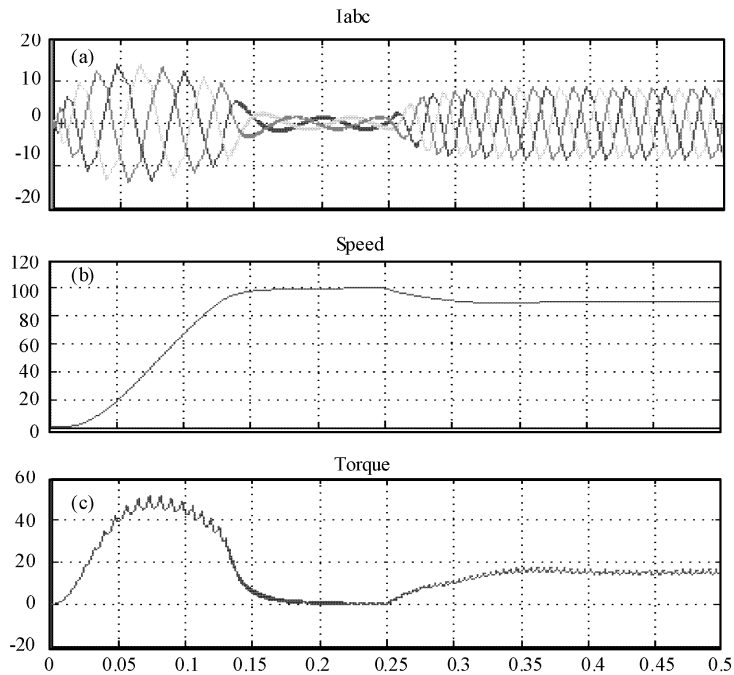

Fig. 7: a) Line currents in Amps, b) Speed in RPS and c) Torque in N-M on step change in load

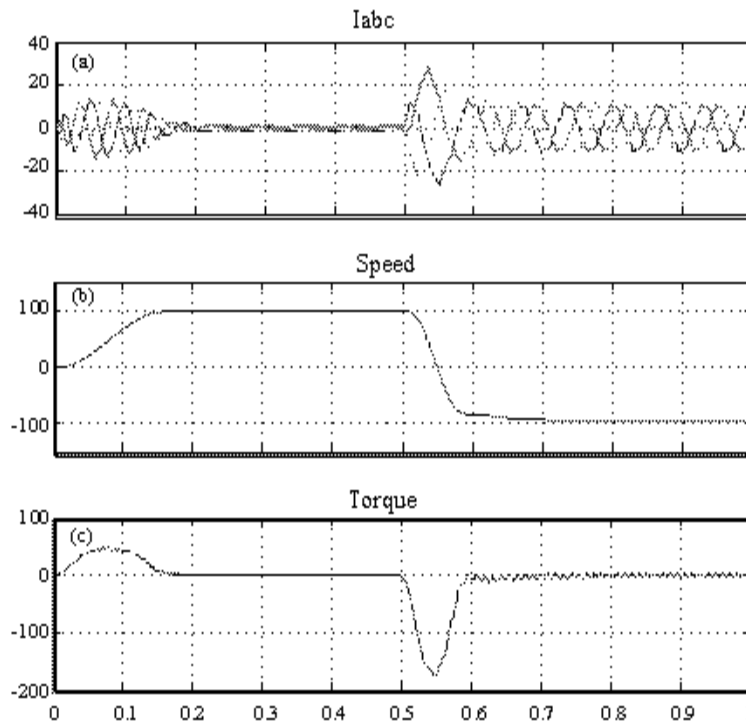

Fig. 8: a) Line currents in amps, b) Speed in RPS and c) Torque in N-M on no load, speed reversal

From the simulation results it is clear that the actual speed is same as the estimated speed and the time transient time is 0.2 sec, which is a sign of fast dynamic convergence. The quadrature and direct axis voltages and currents are displaced exactly by  $90^\circ$ , which indicated that they are de-coupled. Hence, the noise level is less.

**Case 2:**

- Step change in load
- Reference speed  $-100 \text{ rad sec}^{-1}$
- Load torque of 15 N-m is applied at  $t = 0.25 \text{ sec}$

**Comments:** Figure 7 shows the line currents, speed and torque waveforms under load condition. First the motor is started under no load and at  $t = 0.25 \text{ sec}$ , a load of 15 N-m is applied. It can be seen that at 0.25 sec, the values of currents and torque will increase to meet the load demand and at the same time speed of the motor slightly falls.

**Case 3:**

- Speed reversal command
- Reference speed  $-100 \text{ rad sec}^{-1}$
- Speed reversal command is applied at  $t = 0.5 \text{ sec}$

The motor is started under no load and the speed reversal command is applied at  $t = 0.5 \text{ sec}$  as shown in Fig. 8. At 0.5 sec the motor speed decays from

$100 \text{ rad sec}^{-1}$  and within 0.1 sec, it reached its final steady state in the opposite direction. At 0.5 sec torque will increase in the negative reverse direction and reaches a steady position, which corresponds to the steady state value.

**REFERENCES**

Boukas, T.K. and T.G. Habetler, 2004. Nonlinear sensorless speed control for the induction machine utilizing a high-performance embedded DSP. Applied Power Electronics Conference and Exposition. APEC apos; 04. 19th Ann. IEEE, 1: 552-557. DOI: 10.1109/APEC.2004.1295861.

Cao-Minh, T.U.T. and Y. Hori, 2001. MRAS-based speed sensorless control for induction motor drives using instantaneous reactive power. Industrial Electronics Society, IECON. 27th Ann. Conf. IEEE, 2: 1417-1422. ISBN: 0-7803-7108-9. DOI: 10.1109/IECON.2001.975989.

Edward, C.P. and L.A. Thomas, 2008. Modeling and design of controlled current induction motor drive system. Industry Applications. IEEE. Trans., IA-13 (4): 321-330. DOI: 10.1109/TIA.1977.4503414.

Holtz, J., 2002. Sensorless control of induction motor drives. Proc. IEEE, 90 (8): 1359-1394.

- Lee, J.S., T. Takeshita and N. Mastsui, 1997. Stator-flux oriented sensorless induction motor drive for optimum low speed performance. IEEE. Trans. Ind. Appl., 33 (5): 1170-1176. DOI: 10.1109/28.633793.
- Lee, K.B. and F. Blaabjerg, 2006. Sensorless power control for induction motor drives fed by a matrix converter. Industry Applications Conf., 41st IAS Ann. Meeting. Conf. Rec. IEEE, 3 (8-12): 1242-1248. DOI: 10.1109/IAS.2006.256690.
- Peng, F.Z. and T. Fukao, 1993. Robust speed identification for speed sensorless vector control of induction motors. Industry Applications Society Annual Meeting, Conf. Record of the 1993 IEEE, 1 (2-8): 419-426. DOI: 10.1109/IAS.1993.298958.
- Tajima, H., G. Guidi and H. Umida, 2002. Consideration about problems and solutions of speed estimation method and parameter tuning for speed sensorless vector control of induction motor drives. Industry Applications. IEEE Trans., 38 (5): 1282-1289. DOI: 10.1109/TIA.2002.802893.