

## A More Efficient Switching Mode Power Supply

G.I. Ighalo, O. Omorogiuwa and M. Ehiwere  
 Ambrose Alli University, P.M.B 14, Ekpoma, Nigeria

**Abstract:** This study is aimed at realizing a more effective switching mode power supply unit for powering household electronic equipment. To achieve this, the monolithic regulating pulse width modulator, SG3524 was used. This format minimizes cost, size and weight and thus avoids component mismatch problems thereby achieving higher efficiency and stability. As a result, of the choice very good performance characteristics were obtained in the areas of voltage regulations, variation of load current with load increase and maximum power. Comparison between this type of power supply and conventional dissipative method shows its relative merits.

**Key words:** Power supply, switch, frequency, convester, Nigeria

### INTRODUCTION

The recent advances in semiconductor, magnetic and passive technologies make the switching mode power supply more popular choice in the power conversion circuit. Power supply devices are used for controlling, regulating, inverting, rectifying and conversion of available power of one set of characteristic to another set of characteristic to meet specified requirement. The switching mode power supply unit have advantage over the linear (conventional) power supply. While, the linear power supply can only step-down an input voltage to produce a lower output voltage. The switching mode power supply, can both step down and step up unregulated input to produce regulated output (Bucking, 1983). Switching mode power supply typically consist of a power transformer, secondary side rectifier diodes, a switching semiconductor device, a control Integrated Circuit (IC) and peripheral circuit. Beside its basic function of supplying power to the load at the secondary side, it may perform other functions depending on the system. For example a switching mode power supply for colour television receiver must minimize the effect of switching noise on the screen (Bucking, 1983).

If the level of integration of the switching circuitry is not high enough, the additional separate circuit will be required to accommodate all functions. The switching mode power supply can be built either by using the fly-back converter or a forward mode converter. It can function with high frequency switches (in practice a transistor) with varying duty cycle to maintain the output voltage. The output variation caused by the switching is filtered out by a L.C filter. Switching mode power supply can be used to step down a supply

voltage just as a linear supplier does. It can also provide a step up function and an inverted output function. Switching mode power supply are use in most household equipment such as colour television, PCs, monitors etc (Irving, 1985).

### MATERIALS AND METHODS

Consider the specification of the proposed switching mode power supply as given:

Power rating	= 30W
Input voltage	= 150V-250V. a.c
Output voltage	= 110V d.c 12V d.c 5V d.c
Operating frequency	= 20kHz

**Input rectifier and filter circuit:** For a voltage of 220V, The peak voltage will be

$$V_p = 220 \times \sqrt{2} = 311V$$

$$\text{Load Current } I_L = \frac{\text{Power}}{\text{Voltage}} = \frac{30}{311} = 96.4mA$$

The bridge diode chosen is the KBPC 606 and has the following specifications

Forward current $I_f$	= 3.0 A at 50°C
$I_{surge}$	= 125A
Peak reverse voltage	= 600V

**Input filter capacitor:** The expression for calculating the filter capacitance is

$$C = \frac{It}{\Delta v} \quad (1)$$

Where,

- C = Capacitance,  $\mu\text{f}$
- I = Load current, A
- T = Time the capacitor must supply currents, mS
- $\Delta V$  = Allowable peak to peak ripple voltage, V

Assuming a worst-case efficiency of 70% for the power supply then input power pin is

$$P_{IN} = \frac{P_{OUT}}{\eta} = \frac{3.0}{0.7} = 42.8\text{W}$$

$$\text{Load Current } I_L = \frac{\text{Power}}{\text{Voltage}} = \frac{42.8}{311} = 0.13784 = 138\text{mA} \quad (2)$$

Taking 10% of the main voltage as the allowable ripples voltage for 220V a.c and that the capacitor voltage level is maintained for half a cycle of 50Hz (10mS) the capacitance (c) will be

$$C = \frac{It}{\Delta v} = \frac{138 \times 10^{-3} \times 10 \times 10^{-3}}{22} = 62.7\mu\text{F}$$

The capacitor must be able to withstand the peak voltage of 311V. The bridge rectifier chosen has a voltage drop of 1.2V at 3A of full load

Hence,

Peak rectifier voltage of the input capacitor

$$\begin{aligned} V_{PI} &= V_p - 2(V_D) \\ &= 311 - 2(1.2) \\ &= 308.6\text{V} \end{aligned} \quad (3)$$

Thus the minimum rating must be 309V. A capacitor of 68pF, 400v was chosen for the design and is  $C_3$

**Switching transistor:** The transistor chosen is the BU508A. Its specifications are shown below.  
Bus508A High voltage horizontal output (NPN-Si)

- Max B  $V_{CBO}$  = 1500v
- Max B  $V_{CEO}$  = 800V
- Max  $I_C$  = 5A
- Max  $P_D$  = 120W at 25°C
- Typical gain  $h_{fe}$  = 5
- Frequency = 3MHz

This transistor has being chosen because it satisfies all the parameters needed as its rating is more than what

is needed especially the  $V_{CEO}$  that is 800V and so can withstand the surge.

**Pulse Width Modulation (PWM):** The oscillator controls the frequency of the SG3524 and it is programme by  $R_T$  and  $C_T$  according to the approximate formula given in Eq. 4. (Gosling, 1977):

$$\text{Frequency } f = \frac{1.15}{R_T C_T} \quad (4)$$

Where f = frequency,  $C_T$  and  $R_T$  are the frequency determining component for switching to reduce to 20 kHz and  $C = 10\mu\text{f}$

$$R_T = \frac{1.15}{f C_T} \quad (5)$$

To allow for fine-tuning 5.6Ω is accepted for  $R_T$  and a variable resistor of 1 kΩ for  $R_4$

$$\begin{aligned} &= \frac{1.15}{20 \times 10^3 \times 10 \times 10^{-9}} \\ &= 5,750 \Omega \end{aligned}$$

For a load current of 138mA and a gain of 5, the base current drive would be

$$\begin{aligned} &= \frac{138 \times 10^{-3}}{5} \\ &= 27.6\text{mA} \end{aligned}$$

For a  $V_{OUT}$  of 5V for the PWM I.C

$$\begin{aligned} R_B &= \frac{5 - 0.7}{27.6 \times 10^{-3}} \\ &= 155\Omega \end{aligned}$$

Flux saturation dt = 3300G

Core effective Area  $A_c = 1.38\text{cm}^2$

Window area  $A_{ir} = 0.58\text{cm}^2$

Volt Ampere capability = approx. 50VA

The flux density derived to be:

$$B_{max} = \frac{(V_p)10^8}{k f N_p A_e} \quad (6)$$

Where,

- $V_p$  = Impressed primary voltage V
- f = Frequency
- $N_p$  = Primary number of turns
- $A_e$  = Core effective area,  $\text{cm}^2$
- K = 4.44 for sine wave (and push-pull converters).

Since, we are using the forward converter  $k = 4$  for the “B” value chosen to fall into the linear region of the B-H curve  $B_{max} = B_{sat}$  will be a good starting point

$$N_p = \frac{(V_p)10^8}{kfB_{max}Ae}$$

worst case peak voltage will be at the lowest voltage which is 150V for this design (Table 1).

$$\begin{aligned} V_p &= 150 \sqrt{2} \\ &= 212V \text{ (diode drop-22V ripples voltage)} \\ &= 212-23.4 = 188.6V \end{aligned}$$

$$\begin{aligned} NP &= \frac{188.6 \times 108}{4 \times 30 \times 103 \times 1600 \times 1138} \\ &= 106 \text{ turns} \end{aligned}$$

$$\text{Secondary turns} = N_p \frac{V_s}{V_p}$$

$$\text{For 12V, } = 106 \times \frac{12}{188.6} = 6.7 \text{ turns} \approx 7 \text{ turns}$$

$$\text{For 110V, } = 106 \times \frac{110}{188.6} = 61.8 \text{ turns} \approx 62 \text{ turns}$$

$$\text{For 5V } = 106 \times \frac{5}{188.6} = 2.8 \text{ turns} \approx 3 \text{ turns}$$

**Conductor size:**

Primary current  $I_p = 138\text{mA}$

Maximum possible current at 150V will be more and so a factor of 3 will take care of this hence maximum allowable primary current.

$$\begin{aligned} I_p &= 138 \times 3 \text{ (mA)} \\ &= 414\text{mA} \end{aligned}$$

Choosing a current density of 400 circular mile/ampere i.e., 400cm/A. The primary winding requires a size of  $414 \times 10^{-3} \times 400 = 165.6 \text{ c.m}$  which corresponds to the AWG gauge 27, which has a diameter of 0.0164 inches. The secondary current is:

$$\text{For 5V, } I_s = \frac{P}{V} = \frac{30}{5} = 6\text{A}$$

$$\text{For 12V, } I_s = \frac{P}{V} = \frac{30}{12} = 2.5\text{A}$$

Table 1: Core materials and their flux density (hratek, 1981)

Core material	Saturation flux density in kilogauss (100 lines/SQCM)
50/60 H <sub>2</sub> power Transformer steel	16-20
Delta max, orthonol permanorm	1.5
Permalloy	13.7
Molypethmalloy	8.7
Mumetal	6.6
Ferrox cube 3 E2A	3.5

$$\text{For 110V, } I_s = \frac{P}{V} = \frac{30}{102} = 0.27\text{A}$$

With current density = 400c.m/A, Size = 400 c.m /A×6A = 2400 c.m , this corresponds to 17 of AWG table.

For 12V,  $400 \times 2.5 = 1000 \text{ c.m}$ , this corresponds to 21 of AWG table.

For 110V,  $400 \times 0.27 = 108$ , this corresponds to 30 of AWG table.

For the 5V secondary current of 6A, pair of conductors are used most time to reduce sine effect at this high frequency. For that reason a pair of gauge 20 of AWG was used.

**Output rectifier and filter:** For the output rectifier each of the diode must be able to stand a minimum surge forward current of  $I_{fm} = 3.6 I_{out}$  for a forward converter

Where,

$I_{fm}$  = Minimum surge forward current

$$\therefore I_{fm} = 3.6 \times 6 = 21.6\text{A}$$

Higher values of these are recommended. Because of the high frequency operation, fast recovery diodes are the best to be employed at this stage.

The diode employed here is the BYW95C it has the following specification (Jacob and Christos, 1971).

$PIV = 600\text{V}$ ;  $I_f = 3\text{A}$ ;  $I_{surge} = 100\text{A}$ ;  $I_{drop}$  at  $3\text{A} = 1.1\text{V}$

Reverse recovery time = 150ns

The diode was used in 110V and 12V output i.e  $D_5$  and  $D_2$  The D2908c is capable of 6A forward current and has the same parameter as the BYW95C (Jacob and Christos, 1971).

The half wave rectifier is adopted while the ripple filtering demand will be less than 50Hz

$$C_{OUT} = \frac{\Delta I_{OUT}}{8t\Delta V_{OUT}} \tag{7}$$

The formula used here is

Where,

$$I_{out} = 0.25I_c$$

$$I_c = \text{Load current}$$

$$\Delta V_{out} = \text{Allowable PK – PK output voltage ripple}$$

$$F = \text{Operating frequency}$$

Choosing  $\Delta V_{out} = 0.1$

$$C_{out} = \frac{6}{8 \times 20 \times 10^3 \times 0.5} = 375 \mu\text{f}$$

Chose 470  $\mu\text{f}$ , 16V for  $C_8$  as the next closest standard value for better filtration

For the 110V

$$C_{OUT} = \frac{0.27}{8 \times 20 \times 10^3 \times 0.1} = 16.8 \mu\text{f}$$

Chose a value of 22 $\mu\text{f}$ , 160V for  $C_6$

$$C_{out} = \frac{2.5}{8 \times 20 \times 10^3 \times 0.1} = 156 \mu\text{f}$$

Chose 220 $\mu\text{f}$  value, 25V for  $C_7$

**Peripheral and protection circuit:** There are other peripheral circuits and components needed by the switch mode supply to function properly and reliably. These are:

- Self-bias and start up
- Opto-coupler PWM feedback
- Snubber circuit
- Soft starting

**Self bias and start-up:** The function of a self bias circuit is to power the pulse width modulator IC from the high frequency transformer instead of the supply line voltage (Fig. 1). This only supplies a sine voltage.

The resistor  $R_1$  supply a current of  $I_L = P_z/V_z$  to the I.C at start up.

The Zener power rating is 200mW at 9v

$$\text{Then } I_2 = \frac{200 \times 10^{-3}}{9} = 22 \text{mA}$$

$$R_1 = \frac{V_p - V_z}{I_z} \quad (8)$$

$$R_1 = \frac{309 - 9}{22 \times 10^3} = 13.6 \text{k}\Omega$$

Resistor value chosen was 12K $\Omega$

Power rating of resistor =  $I^2R$

$$P = (22 \times 10^{-3})^2 \times 13.636 = 6.5 \text{W}$$

A 10W value was used here

Choose 39 $\Omega$  for the value

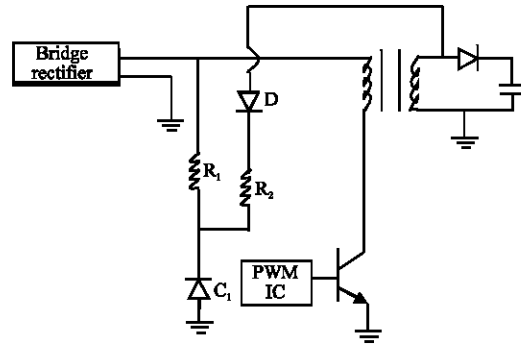

Fig. 1: Self-bias circuit

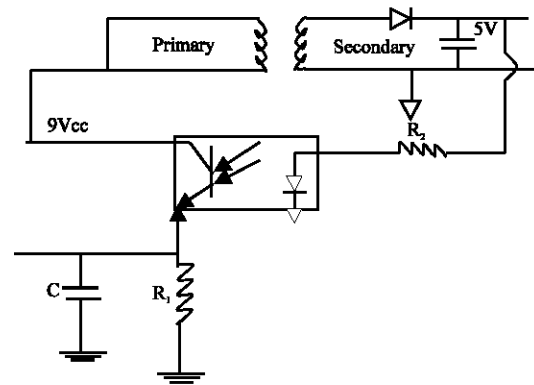

Fig. 2: Opto-coupler feedback P.W.M circuit

Power rating =  $I^2R$

$$R_2 = \frac{12 - V_z}{(22 + 50) \text{mA}} = \frac{12 - 5}{(77 \times 10^{-3})^2} \times 39 = 0.23 \text{W}$$

**Opto-coupler (PWM) feed back:** The regulation control of the pulse width for constant output was realized by the use of the opto-coupler PC 120. Figure 2 shows the opto-coupler feedback

The LED forward voltage is 2.2V and has a forward current of 8mA. Thus using the 5V line as our point of feedback gives:

$$R_7 = \frac{V_{cc} - V_D}{I_F} = \frac{5 - 2.2}{8 \times 10^{-3}} = 350 \Omega$$

**Snubber circuit:** The snubber circuit it intended to help reduce the high voltage spikes developed across the switching transistor usually under inductive loads. It is made up of a resistor and a capacitor,  $R_8$  and  $C_5$ .

The snubber circuit also helps to turn off the transistor at low value of collector to emitter voltage and also reduce collector current with rising collector voltage (Gosling, 1977). The RC Snubber circuit is as shown in Fig. 3.

$D_2$  is a leakage inductance Commutating diode  $D_3$  changes  $C_5$  and so help diverts collector current. It is known that

For  $t_r = 20\mu\text{s}$  and  $t_f = 50\mu\text{F}$

$$C_5 = \frac{138 \times 10^{-3} (70 \times 10^{-6})}{311}$$

$$C_5 = \frac{I_c (t_r + t_f)}{V_{CE} (V_P)} \quad (9)$$

$$= 31 \times 10^9 \text{ f} = 31 \text{ nf}$$

Used a value of 33nF for  $C_5$  as the nearest standard value available

$$R_5 = \frac{t_{on}}{3C}$$

This will corresponds to a discharge rate of 3 time constants. Taking  $T_{on}$  as 60% of full period  
60% of  $\frac{1}{2}$  kHz =  $30\mu\text{s}$   
 $300\Omega$  was chosen

$$R_8 = \frac{30 \times 10^6}{3 \times 33 \times 10^{-9}} = 303\Omega$$

Power rating of the transistor is  $P_R$   
 $= \frac{1}{2} \times 33 \times 10^{-9} (311)^2 \times 20,000$   
31.9w

**Soft starting:** Time constant  $\tau = RC$

For a time constant of 2 sec and  $C = 100\mu\text{F}$  for  $C_4$ .

$18\text{k}\Omega$  was chosen for  $R_2$ , being the closest standard value. This will give a reduce time delay

$$R = \frac{\tau}{C} = \frac{2}{100 \times 10^{-6}} = 20\text{k}\Omega$$

of 1.8 sec which is still okay.

**Line filters element:** The line filter network consisting of  $C_1, C_2, L_1$  and  $L_2$  should be such that they attenuate the noise generated by the switches. At 20 kHz frequency there is resonance.

Where,  $w = 2\pi\text{f}$  and

Choosing a value for  $C = 22\mu\text{F}$

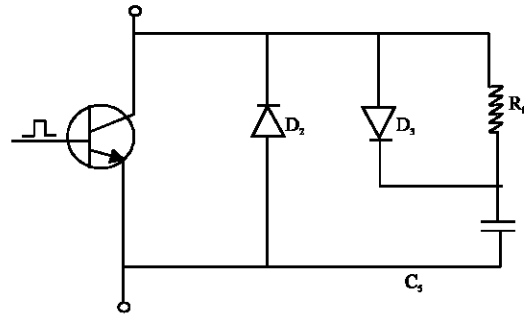

Fig. 3: Turn off Current Snubber Network

$$j\omega L_F + j\omega L_F + \frac{1}{j\omega C_F} + \frac{1}{j\omega C_F} = 0$$

$$j\omega 2L_F + \frac{2}{j\omega C_F} = 0$$

$$L_F = \frac{1}{\omega_2 C}$$

$$\omega^2 + \frac{1}{LC} = 0$$

$$= \frac{1}{(2 \times 20 \times 10^3)^2 \times 2 \times 10^{-6}} = 2.87\mu\text{H}$$

$$L_F = L_1 = L_2$$

$$C_F = C_1 = C_2$$

## RESULTS

Each stage of the circuit was tested and certain parameters and component values adjusted to get the right values of performance. After completion of the whole circuit, defined test was also carried out, which involved open circuit voltage test, maximum load and voltage regulation were conducted.

During testing, the power supply was loaded with a bank of  $47\Omega$  resistors (wire wound choke type) connected successfully in parallel across the output of the power supply. In each instance, the readings were noted using a digital voltmeter and ammeter and these are recorded in table below.

**Test results:** Table 2-4 show the values of the test readings during testing. Each loading condition was done for 5 min.

The maximum load current that could be achieved with the load before over heating of the transistors was with 10 resistors in parallel.

Thus for the supply output:  $-I_{LMAX} = 2.5\text{A}$

Maximum power  $P_{max} = I_L V_L$

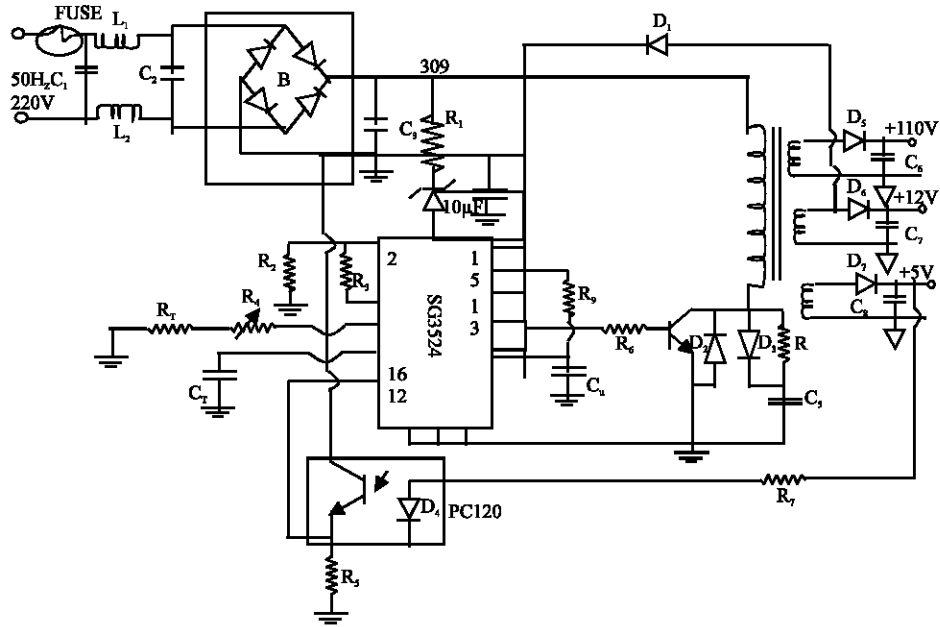

Fig. 4: Complete circuit for switching mode power supply

Table 2: Power supply open circuit test (No load)

Designed value (v)	Power supply measured value (v)
Theoretical	Experimental
110v	109.8V
12V	12.3V
5V	5.2

Table 3: Power supply resistive loading result (12V)

No of 47Ω resistors in parallel	Load current I <sub>L</sub> (A)	Output voltage V <sub>L</sub> (V)	Equivalent resistance R(Ω)
1	0.25	12.18	47.00
2	0.50	12.00	23.50
3	0.76	12.00	15.67
4	1.02	12.00	11.75
5	1.27	11.97	9.40
6	1.52	11.94	7.83
7	1.77	11.93	6.71
8	2.03	11.91	5.87
9	2.26	11.82	5.22
10	2.50	11.76	4.70

Table 4: Input voltage variations and output

Input voltage V	Output voltage V		
	5	12	110
140	4.92	11.89	109.4
150	4.92	11.89	109.5
160	4.93	11.90	109.6
170	4.93	11.90	109.6
180	4.95	11.92	109.7
190	4.95	11.93	109.7
200	4.99	11.98	110.1
210	5.01	12.10	110.1
220	5.01	12.15	110.1
230	5.03	12.20	110.2
240	5.04	12.23	110.3

Where,

V<sub>L</sub> = Load voltage = 12V

I<sub>L</sub> = Load Current

from the test carried out

$$P_{MAX} = 2.5 \times 11.76 = 29.4W$$

Designed power P<sub>10</sub> = 30W

Voltage regulation is given as

Where V<sub>NL</sub> = No load voltage = 12.3V

$$V_{reg} = \frac{(V_{NL} - V_{FL}) \times 100\%}{V_{NL}}$$

$$V_{reg} = \frac{(12.3 - 11.76) \times 100}{12.3}$$

V<sub>FL</sub> = full load voltage = 11.76V

= + 2.5%

= - 2%

$$\therefore V_{out} = 12V(+2.5\%, -2\%)$$

$$V_{reg} = \frac{(12V - 11.76V) \times 100\%}{12}$$

Percentage drift for each output is,

For 5V, between 140-240V,

$$= \frac{5.04 - 4.92}{5} \times 100\% = 2.4\%$$

For 12V,

$$= \frac{12.23 - 11.89}{12} \times 100\% = 2.8\%$$

For 110V,

$$= \frac{110.6 - 109.4}{110} \times 100\% = 0.8\%$$

### **CONCLUSION**

The regulation achieved will suffice for powering radios, cassette players, computers and other electronic systems and circuit. The test input voltage shows that it can be powered from 140-240 V ac.

### **REFERENCES**

- Bucking, M.J., 1983. Noise in Electronic Devices and Systems. Wiley New York. (1st Edn.), pp: 9: 30-53.
- Gosling, W.A., 1977. First Course in Applied Electronics; English; Language Book Society and Macmillan. (2nd Edn.), pp: 293.
- Hratek, E.R., 1981. Design of Solid State Supplies, Van Nostrand Reinhold New York. (1st Edn.), pp: 215-230.
- Irving, M.G., 1985. Power Supplies-Switching Regulators, Inverters and Converters, BPB Publications. (1st Edn.), pp: 213-379.
- Jacob, M. and C.H. Christos, 1971. Integrated Electronics, McGraw-Hill Book Company (1st Edn.), pp: 698-707.